



MODISS[®]



ECLECTIC

Este catálogo de luminarias nace de la pluralidad de las colecciones que Modiss ha seleccionado para esta edición, su gama más ecléctica*.

Un calidoscopio** de luz y técnica, un juego óptico de iluminación y estética (o belleza).
Descubre la nueva luz de Modiss.

This catalog of lighting comes from the plurality of collections Modiss selected for this edition, its eclectic variety.*

*A kaleidoscope** of light and technique, an optical illusion of light and beauty.
Discover the new light of Modiss.*

***ecléctico, -ca. - adj.** relativo al eclecticismo (escuela filosófica)

- Que consta de elementos sacados de diversos sistemas.
- Que trata de conciliar ideas o tendencias de sistemas diversos.
- [Persona] que emplea diferentes tendencias culturales o artísticas.

****calidoscopio. - m,** [del griego: **kalós**, bella; **eidós**, imagen y **scopéo**, observar].

Juego de láminas traslúcidas de color que, por incidencia de la luz, crean figuras que se ven multiplicadas simétricamente, creando una serie infinita de imágenes.

***Eclectic: adj.** relative to the eclecticism (philosophical school)

- Comprised of elements drawn from various systems.
- That attempts to reconcile ideas and trends from various systems.
that uses different cultural and artistic trends

****kaleidoscope:** from the Greek **kalos**, beautiful, **eidós**, image and **scopéo**, watch.

Set of translucent sheets that, by the incidence of the light, create figures that are multiplied symmetrically, creating an infinite series of images.

novidades



alma



icaria



margarita

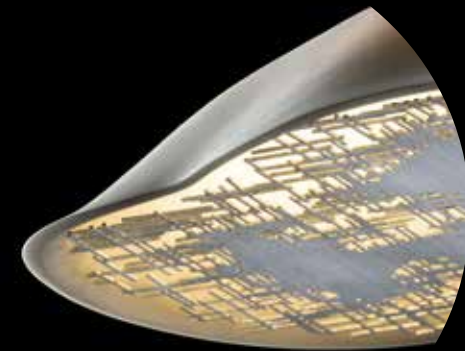



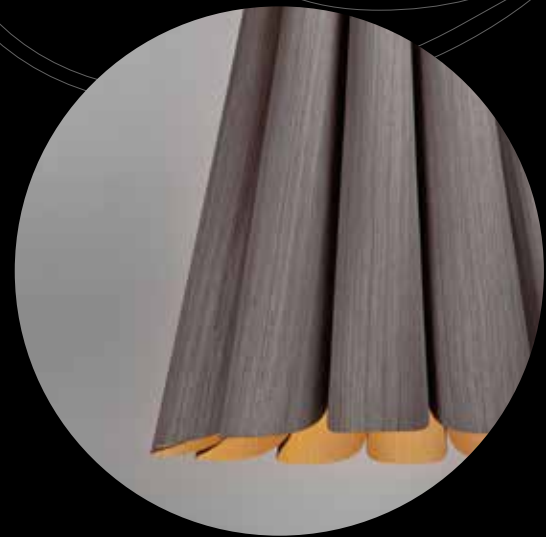















































talissee



zinnia



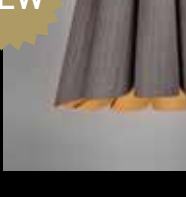



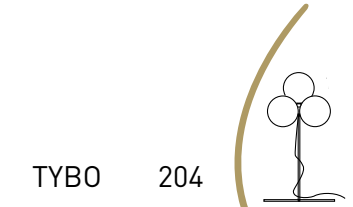
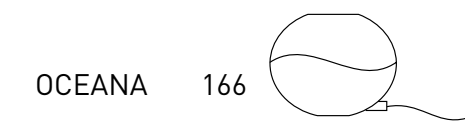
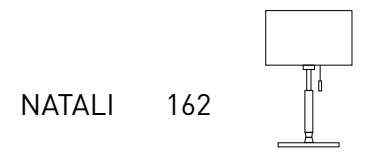
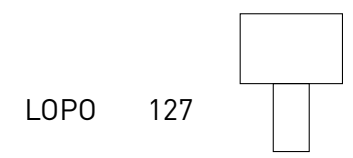
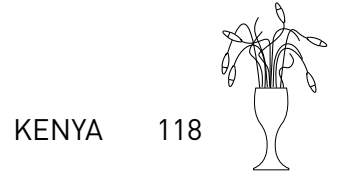
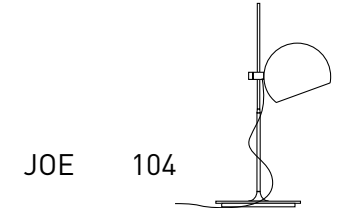
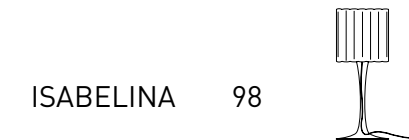
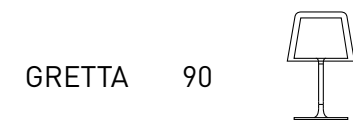
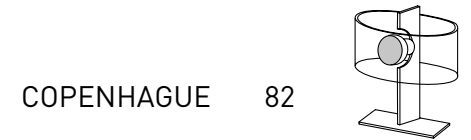
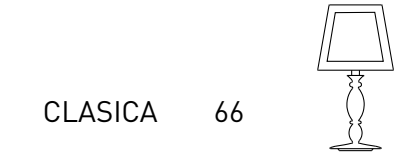
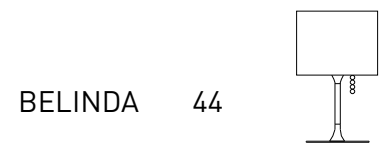





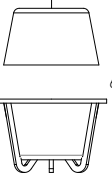
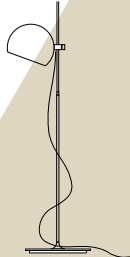
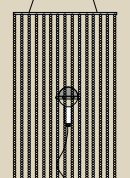

Modiss design collection

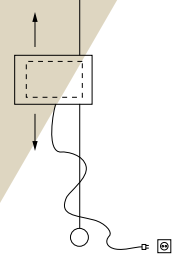
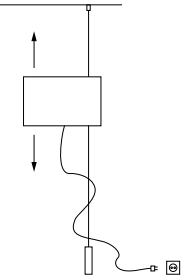
 NEW											
ALMA 17	AMANDA 26	ANDRESSA 32	BALBINA 36	BAMISEL 38	BAMS 40	BARBARA 42	BELINDA 44	BIANCA 48	BISCUIT 51	CARMEN 58	CELEX 62
								 NEW			
CLASICA 65	CLAUDIA 72	CONSTANSSA 75	COPENHAGUE 82	FILIPO 84	FUNGHI 86	GILDA 88	GRETTA 90	ICARIA 94	ISABELINA 88	IVANNA 100	
									 NEW		
JADE 102	JOE 104	JULIA 109	KAIKALA 112	KENYA 117	LOE BLACK 122	LOE CLASSIC 124	LOPO 126	LUCCAS 128	MARGARITA 132	MARIA 138	
											
MARTINA 143	MEDUSA 148	MILES 151	MONNA 156	MOSSI 158	NATALI 162	OCEANA 166	PENELOPE 168	PLAMIRA 172	REBECCA 176		
			 NEW				 NEW				
ROSSANA 180	SERENA 184	SOFIA 188	TALISSE 191	TUSSCANA 198	TYBO 204	VALENTINA 208	ZINNIA 210				

LÁMPARAS DE SOBREMESA · TABLE LAMPS

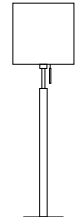
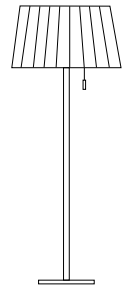
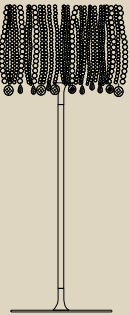

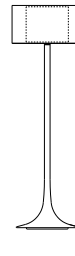
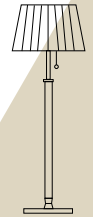
LÁMPARAS DE PIE · FLOOR LAMPS

BELINDA 44		CARMEN 58		CLASICA 68		GILDA 88		GRETTA 90	
NEW ICARIA 94		JOE 104		KAIKALA 112		KENYA 118		LOE BLACK 122	
LOE CLASSIC 124		LOPO 127		LUCCAS 128		NEW MARGARITA 134		MARIA 138	
MARTINA 144		MOSSI 158		NATALI 162		PENELOPE 168		PLAMIRA 172	
TUSSCANA 198		TYBO 204		NEW ZINNIA 212					

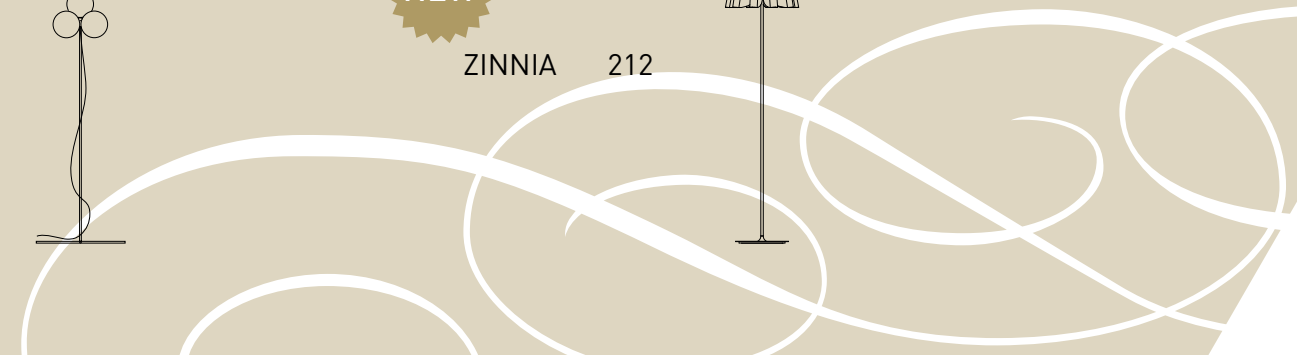

APLIQUES · WALL LAMPS

ANDRESSA 32



BAMS 40

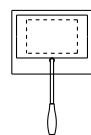

BISCUIT 52

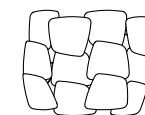

CELEX 62

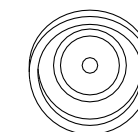

CONSTANSSA 76



FUNGHI 86



JADE 102

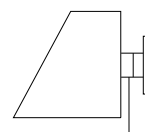

JOE 104



LUCCAS 128

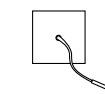

MARIA 140



MOSSI 160

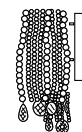

NATALI 164



SERENA 184



TUSSCANA 200

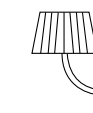

TYBO 206



LÁMPARAS DE TECHO · CEILING LAMPS

NEW

ALMA 18

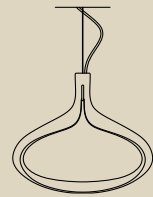

AMANDA 26

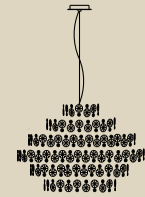

ANDRESSA 32



BALBINA 36



BAMISEL 38

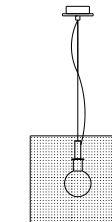

BARBARA 42

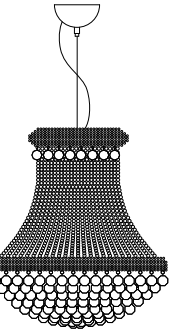

BELINDA 44

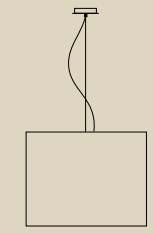

BISCUIT 52

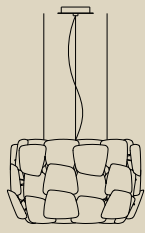

CARMEN 58



CLASICA 70



CONSTANSSA 76



FUNGHI 86

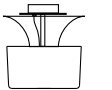

GILDA 88

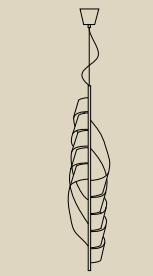

GRETTA 91

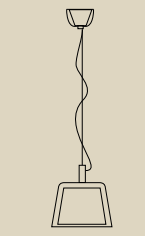

IVANNA 100



JOE 104



JULIA 110

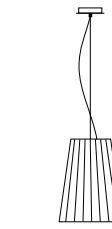

LOPO 127

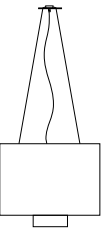

MARGARITA 132

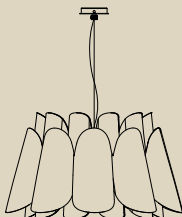

MARIA 140

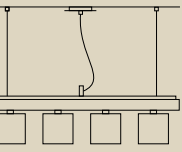

MARTINA 146



MEDUSA 148



MILES 152

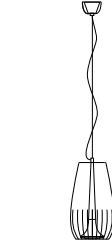

MOSSI 158



NATALI 164

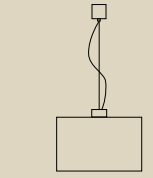

PENELOPE 168

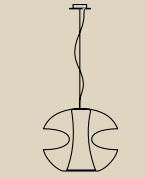

PLAMIRA 174



REBECCA 176



ROSSANA 180

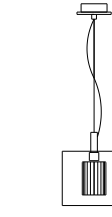

SERENA 184



NEW

TALISSE 192



TUSSCANA 200

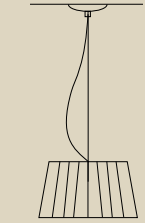

TYBO 206



VALENTINA 208

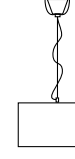

NEW

ZINNIA 210



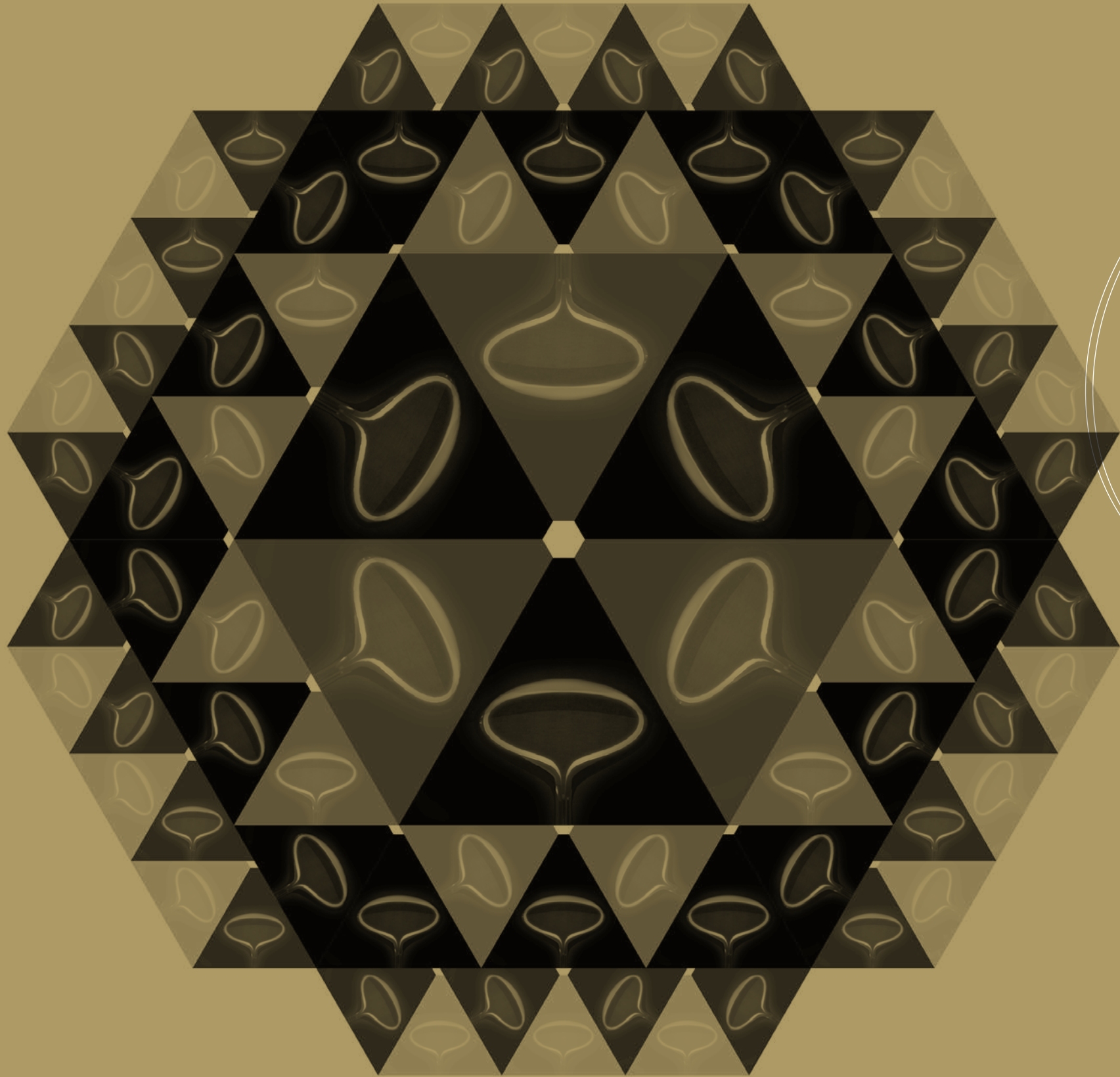

Calma

NEW

alma

DESIGN:
ROGER VANCELLS

Alma es un instante de luz contenida, una pausa envuelta dentro de un contorno que emana sensualidad. Una figura voluptuosa, esculpida mediante un juego de luces y sombras que definen sus formas y acentúan los límites entre su piel exterior e interior... "La sensualidad de un cuerpo en penumbra con un alma ardiente de luz interior"...

Su corazón de tecnología LED escondido en la propia piel baña de luz su espacio interior y proyectando al mismo tiempo un potente haz de luz directo.

El diseño de Alma surge de la búsqueda de una luminaria que se pudiera definir con adjetivos reconocibles en Modiss, una marca mediterránea que transpira sensualidad, originalidad, belleza, expresividad y calidez.

*An endless moment, a glance of light, a pause wrapped on a shape emanating pure sensuality...that's ALMA.
A voluptuous figure shaped on a light-shadow play, defining its form and emphasizing the limits between internal and external skin... "The sensuality of a body under cover of darkness with an internal passionate light"...*

The heart of Alma is hidden under her skin; using LED technology bathes her soul projecting, at the same time, a powerful and direct beam.

Alma's design is the result of a hunt to create a luminaire that can be defined by Modiss accent, a Mediterranean brand that emanates sensuality, originality, beauty, eloquence and charm.

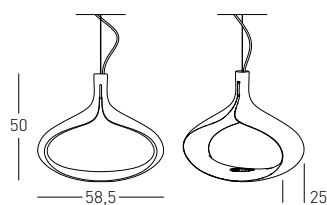

ALMA

Colgante individual
Single suspension
Peso / Weight 6,00 kg

2 x LED 20 W - 220 V
Luz directa e indirecta
Direct and indirect light



PANTALLA

Composite
Interior: Dorado / Blanco
Exterior: Negro / Blanco / Granate
CABLE
Rojo
Negro (para modelo granate)

SHADE

Composite
Inside: Gold / White
Outside: Black / White / Deep red

WIRE

Red
Black (for deep red model)















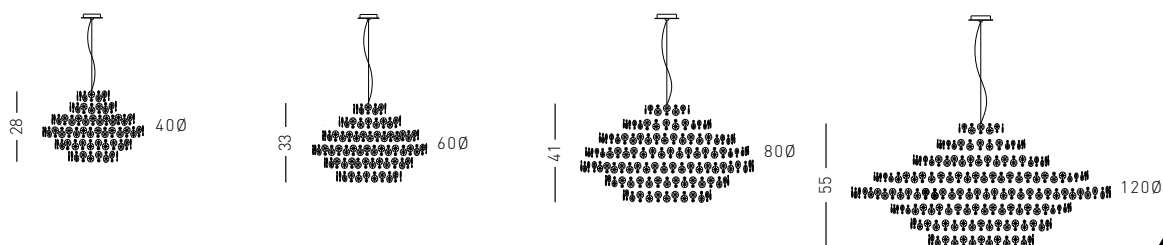

Amanda

DESIGN:
MODISS DESIGN TEAM

Lujo, calma y voluptuosidad. El sugerente título de uno de los primeros cuadros de Henri Matisse le sienta como anillo al dedo a una de las menos comunes fuentes de iluminación imaginables. Una fantasía de crystal con el más sofisticado juego de luces, para el deleite de los sentidos en una inimitable atmósfera de sensualidad.

Luxe, calme et volupté. The suggestive title of one of Henri Matisse's first paintings fits like a glove onto one of the least common light sources imaginable. A fantasy of glass with the most sophisticated set of lights to delight the senses in an inimitable atmosphere of sensuality.



AMANDA 1C40	AMANDA 1C60	AMANDA 1C80	AMANDA 1C120
Colgante individual Single suspension Peso / Weight 13,50 kg	Colgante individual Single suspension Peso / Weight 18,50 kg	Colgante individual Single suspension Peso / Weight 33,00 kg	Colgante individual Single suspension Peso / Weight 40,50 kg
8 x G-9 33 W GU-10 50 W	16 x G-9 33 W GU-10 75 W	24 x G-9 33 W GU-10 75 W	36 x G-9 33 W GU-10 75 W
 	 	 	 

MADE WITH SWAROVSKI® ELEMENTS
HECHO CON SWAROVSKI® ELEMENTS

PANTALLA
Tallado octogonal transparente
Strass® Swarovski® Crystal

METAL
Cromo brillo

CABLE
Textil negro

SHADE
Carved octognal transparent
Strass® Swarovski® Crystal

METAL
Chrome
WIRE
Black textile



Campana

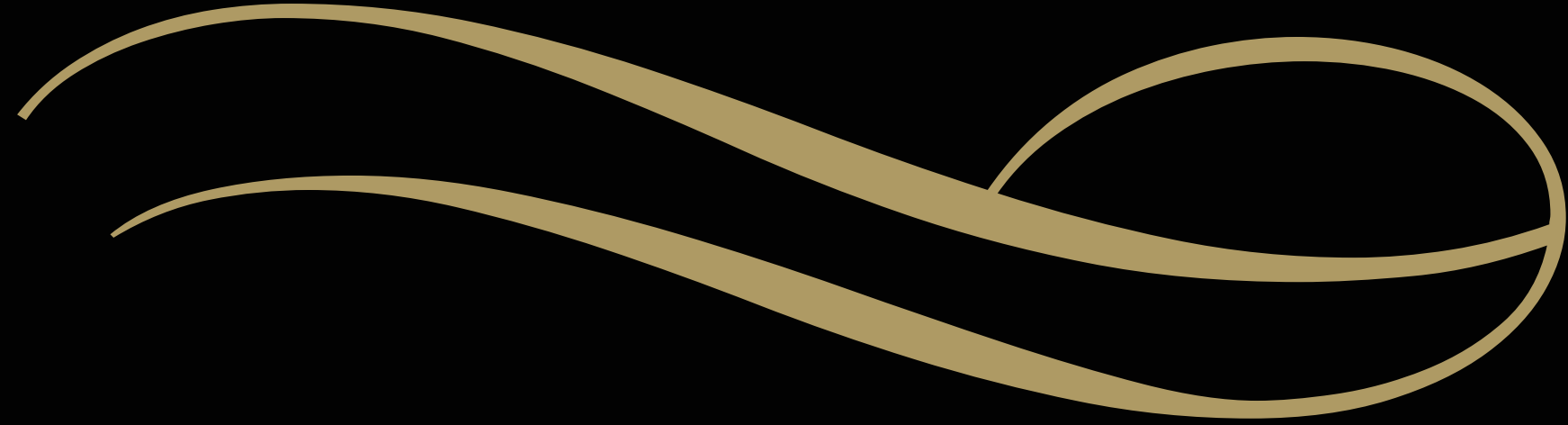



andressa

DESIGN:
MODISS DESIGN TEAM

¡Hágase la luz sobre los cuerpos trémulos de pasión! La divina frase de la creación resuena ante el deseo sublimado, ante el fuego en la piel, ante la pulsión abrasadora de los amantes que se buscan para fundirse en un ahogado éxtasis de placer. Y yo me pregunto: ¿Por qué las palabras lujo y lujuria se parecerán tanto?

Let there be light on bodies trembling with passion! This [almost] divine phrase of creation resounds in the face of sublimated desire, skin on fire, the burning passion of lovers who search each other out to melt into a suffocating ecstasy of pleasure. Why do the words luxury and lust sound so similar?



ANDRESSA 10	ANDRESSA 20	ANDRESSA 1C10	ANDRESSA 1C20	ANDRESSA 1AP10	ANDRESSA 1AP20
Sobremesa Table lamp	Sobremesa Table lamp	Colgante individual Single suspension Peso / Weight 4,00 kg	Colgante individual Single suspension Peso / Weight 6,50 kg	Aplique / plafón Wall lamp / ceiling lamp	Aplique / plafón Wall lamp / ceiling lamp
3 x G-9 20 W	3 x G-9 20 W	3 x G-9 20 W 1 x GU-10 50 W	3 x G-9 20 W 1 x GU-10 50 W	3 x G-9 20 W	3 x G-9 20 W

CUERPO / FLORÓN

Fibra de vidrio lacado blanco brillo
Fibra de vidrio lacado negro brillo
Fibra de vidrio lacado plata
Fibra de vidrio lacado oro viejo

PANTALLA

Cristal bohemia tallado

CABLE

Transparente

BODY / CANOPY

White bright lacquered fiber glass
Black bright lacquered fiber glass
Silver lacquered fiber glass
Old gold lacquered fiber glass

SHADE

Carved bohemian crystal

WIRE

Transparent

Capdresca



Balbina

DESIGN:
MODISS DESIGN TEAM

De la unión entre la calidez de las antiguas lámparas clásicas y los nuevos puntos de luz del presente, nace la bella Balbina. A través de esta extraña pirueta hacia el pasado, se reinterpretan las formas, se reinventa el futuro y, fusionando clasicismo y modernidad, se rinde homenaje al diseño de otros tiempos.

From the union of the remarkable quality of classic lamps from the past and new points of light from the present arises the beautiful Balbina. Through this unique nod at the past, we have reinterpreted shapes, reinvented the future and, fusing classicism and modernity, paid tribute to design from another age.

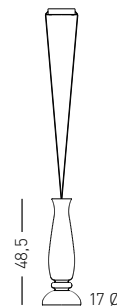

BALBINA 1C20

Colgante individual
Single suspension
Peso / Weight 4,00 kg

GU-10 75 W



CRISTAL
Borosilicato liso
METAL
Cromo brillo
Oro satinado

GLASS
Smooth Borosilicate
METAL
Chrome
Satin gold



Bamisel

DESIGN:
MODISS DESIGN TEAM

Debemos reconocerlo, la luz perdería encanto si no fuera por las sombras, esos pequeños fragmentos de oscuridad, tan presentes y sin embargo olvidados, los que regalan volumen sin ocupar espacio.

Bamisel no sólo te dará una luz llena de matices, sino que dibujará para ti las más bellas sombras.

We should never forget that light would lose its charm if it weren't for shadows, those small fragments of darkness, so dramatically present yet so often forgotten, that provide volume without occupying space.

Bamisel will not only offer you a light full of nuances, but will also draw out the most beautiful shadows.

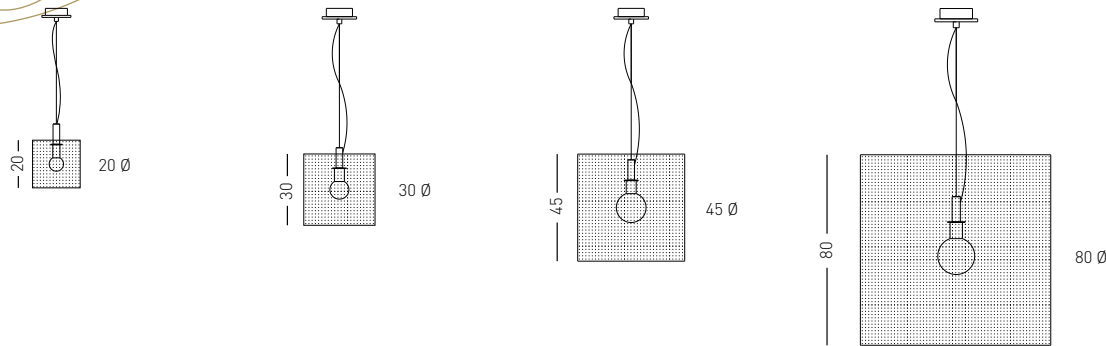

BAMISEL 1C20	BAMISEL 1C30	BAMISEL 1C45	BAMISEL 1C80
Colgante individual Single suspension Peso / Weight 2,00 kg	Colgante individual Single suspension Peso / Weight 3,50 kg	Colgante individual Single suspension Peso / Weight 3,50 kg	Colgante individual Single suspension Peso / Weight 7,00 kg
E-14 42 W	E-27 42 W	E-27 52 / 70 W	3 x E-27 70 W



PANTALLA
Pantalla polypiel perforada blanca
Pantalla polypiel perforada negra
METAL
Cromo brillo
CABLE
Textil rojo

SHADE
White drilled leatherette
Black drilled leatherette
METAL
Bright chrome
WIRE
Red textile







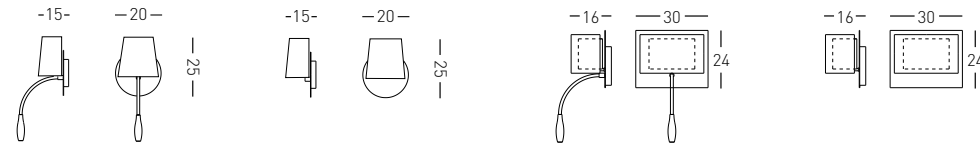

bams

DESIGN:
B. LOFT & MODISS DESIGN TEAM

La luz de la luna tiene un extraño influjo sobre el ánimo de algunas personas. La luz de estas lámparas, sin duda, también. Bajo ellas pueden dibujarse expresiones plenas de ternura, pueden leerse historias que conmuevan hasta la lágrima, pueden planearse audaces pasiones o pueden soñarse los más prometedores proyectos de futuro.

Moonlight can have a strange effect on some people's mood. The same could be said for the light from these lamps. The light from these lamps can reveal expressions of exquisite tenderness, hear heartbreaking stories that bring forth tears, bear witness to bold passions or share in the most promising projects of the future.



BAMS CONIC AP20	BAMS CONIC AP25	BAMS LONG AP20	BAMS LONG AP25
Aplique Wall lamp	Aplique Wall lamp	Aplique Wall lamp	Aplique Wall lamp
LED 3 W - 700 mA E-14 42 W	E-14 42 W	LED 3 W - 700 mA E-14 42 W	E-14 42 W
 		 	



BAMS LONG

PANTALLA

EXTERIOR: Tela organza blanca
Tela organza negra
INTERIOR: Pergamino poliéster blanco
METAL
Cromo satinado
Lacado blanco / Lacado negro

SHADE

OUTER: White organza cloth
Black organza cloth
INTERIOR: White polyester parchment
METAL
Satin chrome
White lacquered / Black lacquered

BAMS CONIC

PANTALLA

Polypiel perforada blanca
Polypiel perforada negra
METAL
Cromo brillante
Oro satinado

SHADE

White drilled leatherette
Black drilled leatherette
METAL
Bright chrome
Satin gold

barbara

DESIGN:
MODISS DESIGN TEAM

Los acontecimientos se repiten en la historia.
Los realmente importantes realzan el encuentro entre culturas.
Son clásicos, pero al mismo tiempo, en su ir y venir no se pierden en la actualidad.
Majestuosa y bella, envolviendo el ambiente y llenándolo con su presencia.
Una clara apuesta por el rediseño de un valuarte clásico.

*History repeats itself.
Really important events highlight an encounter between cultures.
They are classical, but at the same time, in their comings and goings, they are not lost in modernity.
Majestic and beautiful, enveloping the atmosphere and filling it with its presence.
A clear commitment to redesign a traditional classic.*

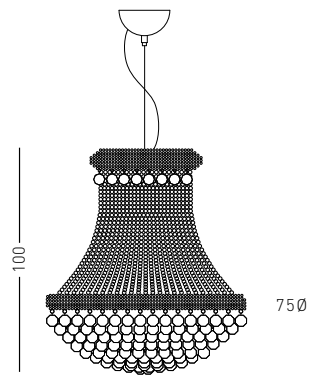

BARBARA

Colgante individual
Single suspension
Peso / Weight 50,00 kg

33 x E-14 28 W



PANTALLA
ASF0UR Crystal 6.325 bolas
METAL
Estructura cromo
CABLE
Textil rojo

SHADE
ASF0UR Crystal 6.325 balls
METAL
Chrome Structure
WIRE
Red textile



Belinda

DESIGN:
MODISS DESIGN TEAM

Al principio de la colección tenía en la cabeza una idea hermosa y sencilla.

Para no dejarla escapar quise modelar un prototipo con un pie noble en aluminio, rematado por una pantalla circular proporcionada, sin estridencias.

La relación con la pieza se estrechaba a medida que avanzábamos. Al final del camino se encarnó frente a mí y sentí que tenía frío; la arropé con terciopelo. Entonces me habló, me susurró su nombre.

At the beginning of the collection, I had a beautiful and simple idea in my head. So as not to let it escape, I wanted to model a prototype with a noble aluminium foot, crowned by a proportionate circular shade, without excesses.

The relationship with the piece became closer as we advanced. At the end of the road, it was there in front of me and I felt it was cold; I clothed it with velvet. And then it spoke and whispered its name to me.

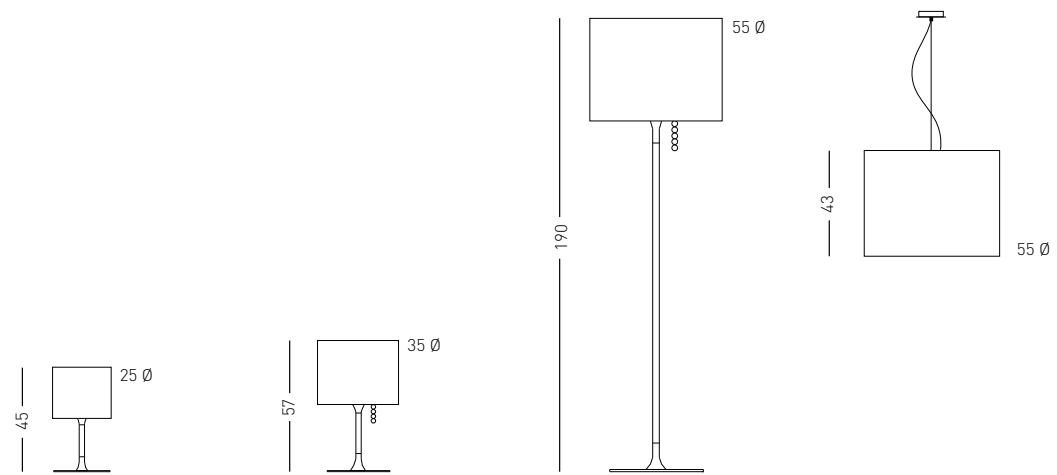

BELINDA 10	BELINDA 20	BELINDA 50	BELINDA 1C50
Sobremesa Table lamp	Sobremesa Table lamp	Pie salón Floor lamp	Colgante individual Single suspension Peso / Weight 6,50 kg
E-27 42 W	E-27 42 W	E-27 52 / 70 W	E-27 52 / 70 W

PANTALLA
Terciopelo blanco
Terciopelo negro
Terciopelo limón
METAL
Aluminio satinado
CABLE
Transparente

SHADE
White velvet
Black velvet
Lemon velvet
METAL
Satin aluminium
WIRE
Transparent



belinda



Bianca

DESIGN:
MODISS DESIGN TEAM

En decoración e interiorismo, los creadores anhelamos la pureza, pero... ¿qué es, la pureza? ¿La sobriedad del color blanco? ¿La transparencia del cristal? ¿La aparente simplicidad de las líneas armónicas?

Esta vez no tengo dudas. La cualidad más preciada, el secreto mejor guardado, la clave para el estilo está a la vista: reposa en el corazón de Bianca.

In decoration and interior design, we creators aspire to purity but... what is purity? The sobriety of white? The transparency of glass? The apparent simplicity of harmonic lines? This time round I have no doubts. The most precious quality, the best guarded secret, the key to style is on show: it is in the heart of Bianca.

CRISTAL
Opal blanco
CABLE
Transparente

GLASS
White glass
WIRE
Transparent

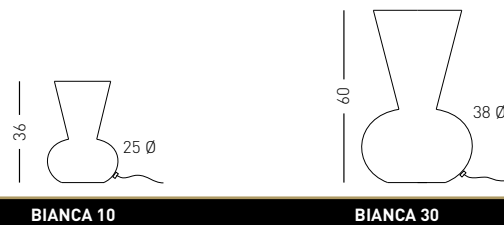

BIANCA 10

Sobremesa
Table lamp

E-27 11 / 19 W
Bajo consumo
Energy saving



BIANCA 30

Sobremesa
Table lamp

E-27 15 / 25 W
Bajo consumo
Energy saving



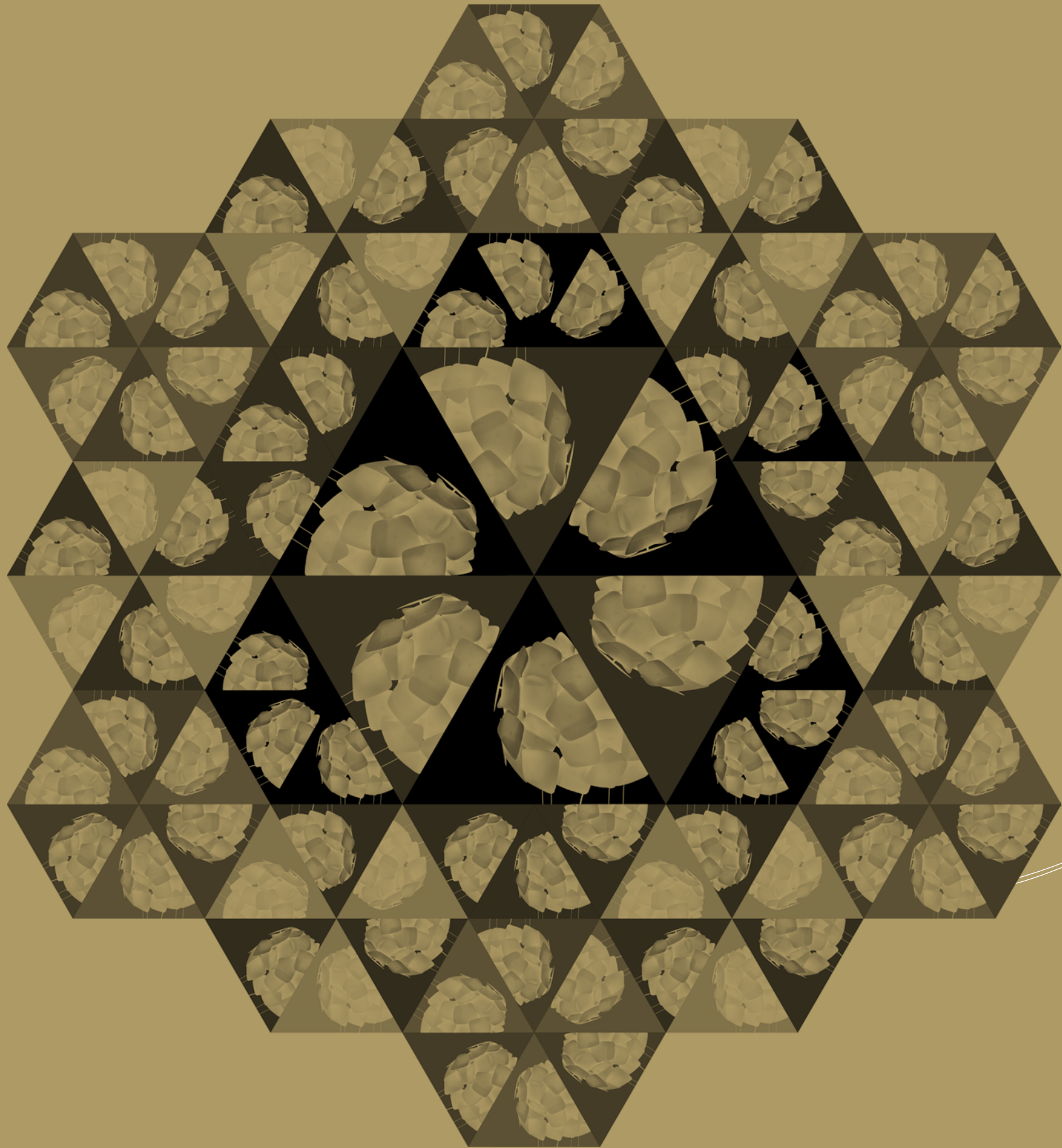

Biscuit

Biscuit

DESIGN:
LAGRANJA DESIGN

Acostumbrados a identificar la porcelana con vajillas y figuritas a veces nos olvidamos que, en capas muy finas, es un excelente difusor de luz.

En estos años hemos diseñado muchas lámparas con materiales nuevos y tecnológicos. Escoger la porcelana es un poco el capricho de volver atrás, de utilizar un material antiguo, un proceso totalmente artesanal hecho con cariño y paciencia, de buscar la calidez por encima de las formas, la sutil imperfección como valor añadido y no como defecto.

Razones de sobra para involucrar en el proyecto a los amigos de Sargadelos, que conocen y saben trabajar la porcelana como pocos.

Perdidos en un pueblo de Galicia entre hornos y moldes de escayola nos pareció que no hacía falta buscar un nombre para la lámpara. Que Biscuit, el nombre que se le da a la primera cocción de la porcelana, iba de maravilla.

Biscuit es una familia lámparas que gracias a la repetición de un módulo de forma orgánica genera una superposición de luces y sombras. Se fabrica en diferentes formas y tamaños.

Used to identify porcelain with tableware and figurines sometimes we forget that, in very thin layers, it is an excellent light diffuser. In these years we have designed many lamps with new and technological materials. Choosing the porcelain is a little caprice to go back, to use an ancient material, a process done entirely handmade with love and patience, to seek the warmth over the shapes, the subtle imperfection as an added value and not as a defect.

The above mentioned are reasons to engage in the project Sargadelos' friends, who know and can work porcelain as few people can. Lost in a village in Galicia between furnaces and plaster casts it seemed to us that there was not need to find a name for the lamp. That Biscuit, the name given to the first firing of porcelain process, was great.

Biscuit is a family of lamps that, thanks to the repetition of an organic shape module, generates a superposition of light and shadow. It is manufactured in different shapes and sizes.

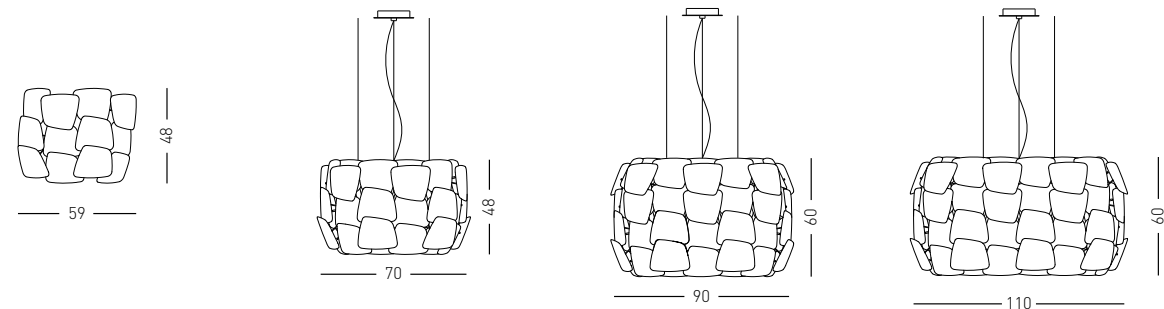

BISCUIT AP10	BISCUIT 1C70	BISCUIT 1C90	BISCUIT 1C110
Aplique Wall light Peso / Weight 2,60 kg	Colgante individual Single suspension Peso / Weight 10,80 kg	Colgante individual Single suspension Peso / Weight 12,50 kg	Colgante individual Single suspension Peso / Weight 14,30 kg
2 x G-9 33 W	3 x G-9 33 W	3 x G-9 33 W	4 x G-9 33 W



PANTALLA
Porcelana Sargadelos
METAL
Acero lacado
CABLE
Blanco

SHADE
Sargadelos porcelain
METAL
Lacquered steel
WIRE
White







carmen

DESIGN:
MODISS DESIGN TEAM

Dieciséis días después de los fuegos artificiales el aire en Boardwalk olía a frío atlántico, a sal, a caparazón hueco. Y apareciste. Y el viento se tornó brisa mediterránea, apacible, cálida y dulce. El tiempo pasó demasiado rápido, Carmen, pero nos regaló estos reflejos grises y naranja. Son mi faro y me muestran el camino al navegar.

Aquí te amo y en vano te oculta el horizonte.
Te estoy amando aún entre estas frías cosas.
A veces van mis besos en esos barcos graves (...)

Pablo Neruda

Sixteen days after the fireworks the air on the boardwalk smelt of the cold Atlantic, of salt, of hollow shells. And you appeared. And the wind turned into a Mediterranean breeze, pleasant, warm and gentle. Time went by too quickly, Carmen, but it gave us these grey and orange reflections. They are my lighthouse and they show me the course I have to sail.

*Here I love you and in vain the horizon hides you.
I love you even among these cold things.
Sometimes my kisses go in those laden ships (...)*

Pablo Neruda

METACRILATO
Naranja
Gris ahumado
METAL
Cromo
CABLE
Transparente

METHACRYLATE
Orange
Tinted grey
METAL
Chrome
WIRE
Transparent

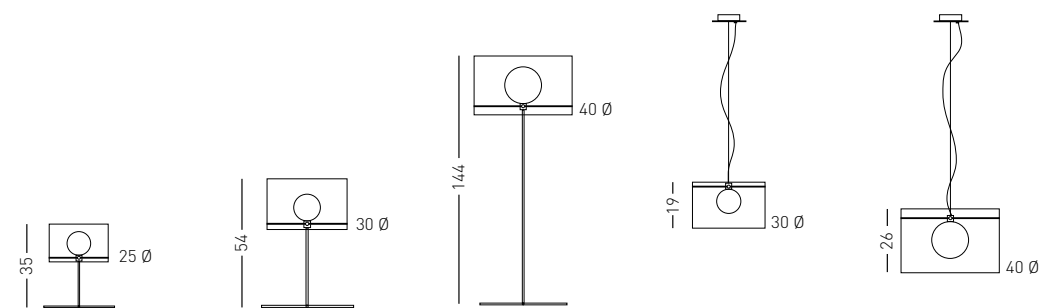

CARMEN 10	CARMEN 30	CARMEN 50	CARMEN 1C30	CARMEN 1C40
Sobremesa Table lamp	Sobremesa Table lamp	Pie salón Floor lamp	Colgante individual Single suspension Peso / Weight 2,50 kg	Colgante individual Single suspension Peso / Weight 3,50 kg
G-9 33 W	G-9 48 W	G-9 48 W	G-9 48 W	G-9 48 W

carmen



celex

DESIGN:
BURKHARD DÄMMER

Por cada par de ojos que miran, hay una forma diferente de ver la vida.
La mirada es una actitud personal que conviene educar porque con frecuencia nos engaña.

Nada lo dice mejor que el bonito verso de Antonio Machado:

"El ojo que ves no es
ojo porque tú lo veas;
es ojo porque te ve."

Every watching pair of eyes sees life in a different way.

A vision is a personal attitude that needs to be fashioned, because we often deceive ourselves.

Nothing sums this up better than a verse by Antonio Machado:

*"The eye you see is not
an eye because you see it;
it is an eye because it sees you."*

— 16 —

35 Ø

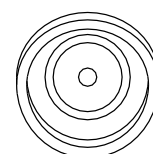

CELEX

Aplique
Wall light

3 x G-9 48 W



CUERPO

Fibra de vidrio lacado blanco brillo

METAL

Cromo brillo

DIFUSOR

Cristal arenado

BODY

White lacquered fiber glass

METAL

Bright chrome

GLASS

Sandy



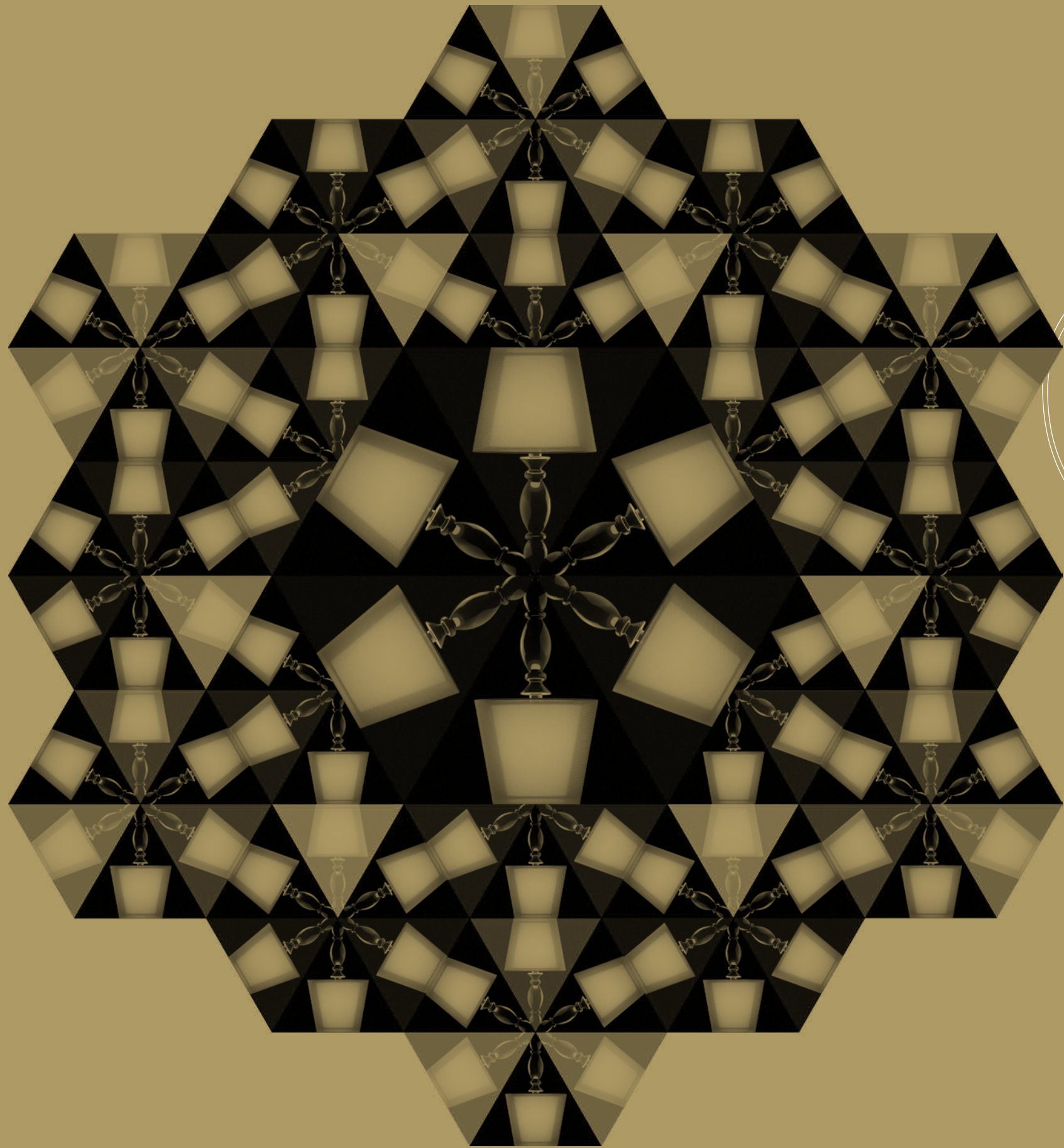

Classica

Clásica

DESIGN:
MODISS DESIGN TEAM

Doble pantalla en transparencias y tela para una iluminación de marcado carácter ambiental. Una gran ocasión para reivindicar el clasicismo que, como todo el mundo sabe, es lo que sobrevive al paso de muchas modas y tiene un valor que ha superado la prueba del tiempo.

A double transparent and fabric shade for distinctly atmospheric lighting. A great opportunity to champion classicism, which, as everyone well knows, is what endures through the vagaries of fashion and whose value has survived the passing of time.

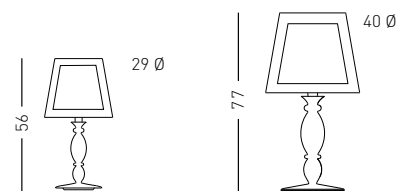

CLASICA 10

CLASICA 30

Sobremesa
Table lamp

Sobremesa
Table lamp

E-14 42 W

E-27 52 / 70 W

Regulador de luz
Intensity dimmer

Regulador de luz táctil
Tactile intensity dimmer



PANTALLA

EXTERIOR: Tela calada negra
INTERIOR: Pergamino poliéster blanco

CUERPO

Fibra de vidrio lacado blanco brillo
Fibra de vidrio lacado negro brillo

CABLE

Transparente

SHADE

OUTER: Black drilled cloth
INTERIOR: White polyester parchment

BODY

White lacquered fiber glass
Black lacquered fiber glass

WIRE

Transparent



Clasica

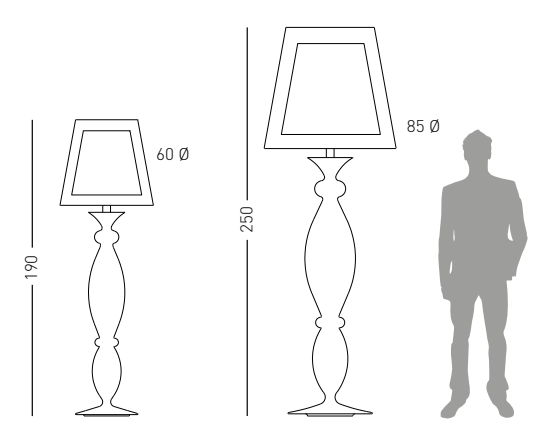

CLASICA 60

CLASICA 80

Pie salón
Floor lamp

Pie salón
Floor lamp

3 x E-27 52 / 70 W

3 x E-27 52 / 70 W

Regulador de luz
Intensity dimmer

Regulador de luz
Intensity dimmer



Regulador de luz en Strass® Swarovski® Crystal
Intensity dimmer with Strass® Swarovski® Crystal

Swarovski® y Strass® son marcas registradas de Swarovski AG

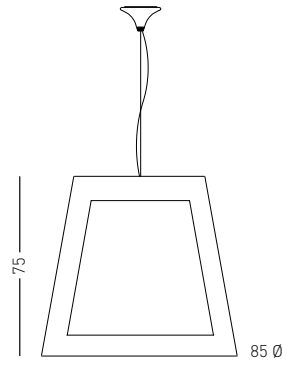
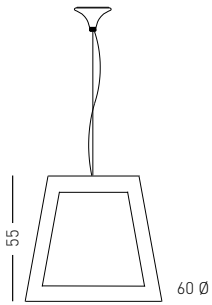

CLASICA 1C60

Colgante individual
Single suspension
Peso / Weight 4,00 kg

3 x E-27 52 / 70 W



CLASICA 1C80

Colgante individual
Single suspension
Peso / Weight 11,0 kg

3 x E-27 52 / 70 W



Claudia

DESIGN:
MODISS DESIGN TEAM

(...) nadar sabe mi llama el agua fría,
perder el respeto a ley severa.
Amor constante más allá de la muerte (fragmento), Francisco de Quevedo.

El barroco es un momento de reflexión y acción, de introspección y exhibición, de exceso, de poesía, de arte... Quevedo sabe que por amor puede perderse el respeto incluso a las leyes de la naturaleza. Así pues, ¿por qué no vamos a remover los pilares de las convenciones si tenemos una llama de terciopelo a nuestro alcance?

(...) my flame knows how to swim the cold water,
and to lose the respect for the severe law.
Constant love beyond death (fragment), Francisco de Quevedo.

The Baroque era is a time of reflection and action, introspection and exhibition, excesses, of poetry, art... Quevedo knows that because of love, one can even lose the respect for the laws of nature. Then, why shouldn't we move the pillars of convention if we have a velvet flame within our reach?

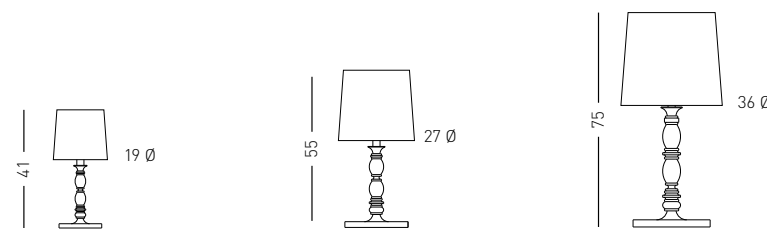

CLAUDIA 10

Sobremesa
Table lamp

E-14 42 W



CLAUDIA 20

Sobremesa
Table lamp

E-27 52 / 70 W



CLAUDIA 30

Sobremesa
Table lamp

3 x G-9 48 W



PANTALLA

Terciopelo blanco
Terciopelo negro
Terciopelo limón

PIE

Cristal transparente

CABLE

Transparente

SHADE

White velvet
Black velvet
Lemon velvet

BASE

Transparent crystal

WIRE

Transparent

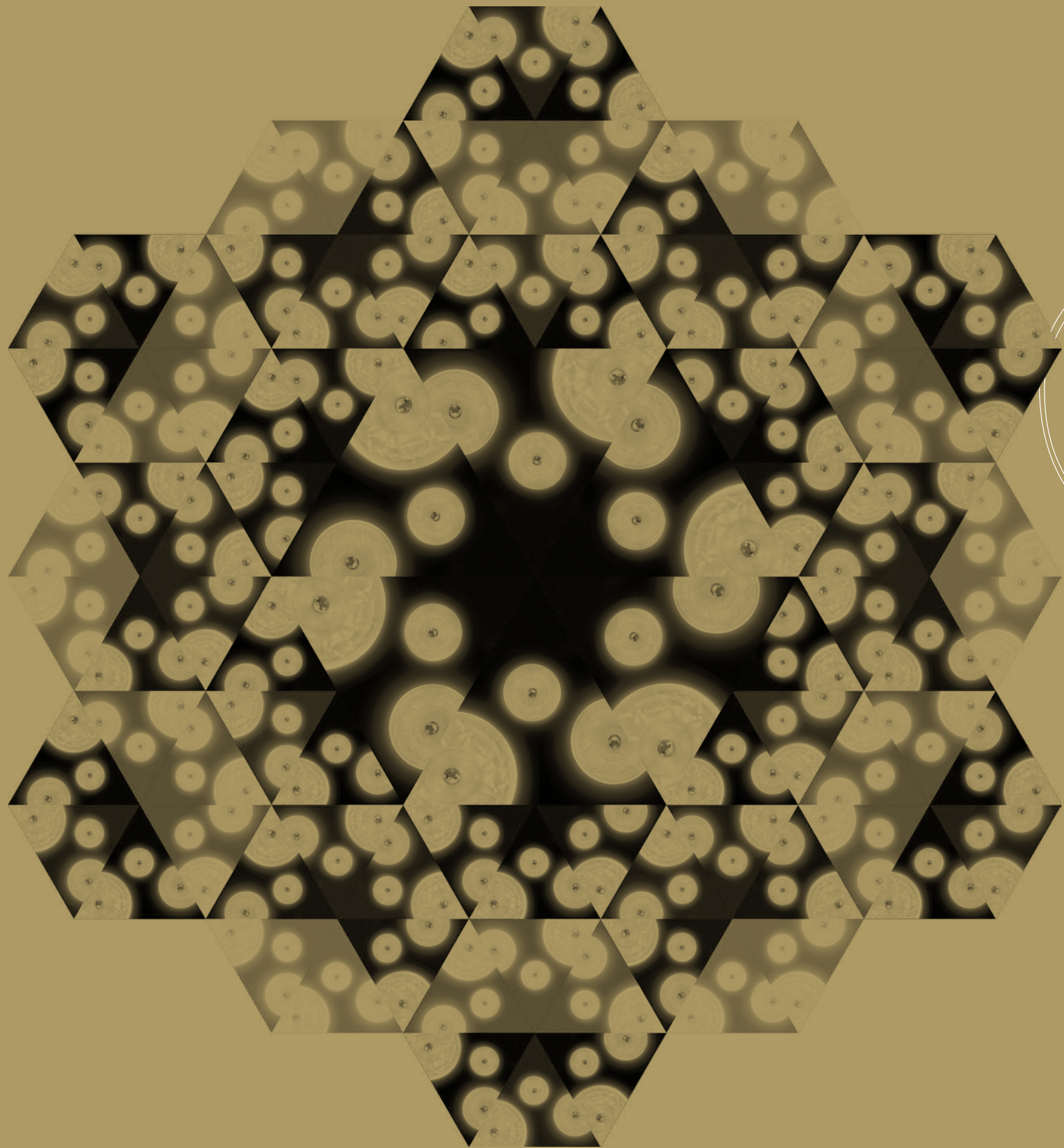

constanSSa

Constanssa

DESIGN:
MODISS DESIGN TEAM, ESTELA & NEREO

El diseño Constanssa convierte la luz en un objeto arquitectónico exclusivo e innovador. La perfecta combinación de una estética contemporánea y barroca emana de forma impactante al contemplar sus líneas orgánicas y el grabado de cada uno de sus infinitos detalles. Constanssa se fabrica artesanal y manualmente con resina glaseada por ello, cuando se ilumina, cada plafón se convierte en una pieza única integrándose perfectamente en el espacio haciendo que la buena arquitectura sea aún mejor. Constanssa se completa con una exquisita pieza de sujeción central de cristal tallado.

The design of Constanssa turns light into an exclusive and innovative architectural light object. The perfect combination of both contemporary and barroc aesthetics rise at first glance when admiring its organic lines and the amazing countless details of the engraved shape. Constanssa is handcrafted individually by artisans with glasse resin material and, when light comes out, each Constanssa becomes an unique piece of art perfectly integrated on the space making good architecture even better. Constanssa is finished with a refined crystal carved central holder.

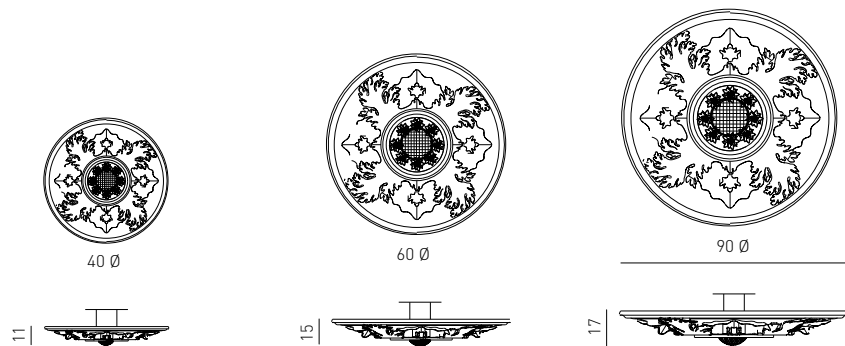

CONSTANSSA 1PL40

Aplique / plafón
Wall lamp / ceiling lamp

3 x E-14 9 W
Bajo consumo
Energy saving



CONSTANSSA 1PL60

Aplique / plafón
Wall lamp / ceiling lamp

4 x E-27 21 W
Bajo consumo
Energy saving



CONSTANSSA 1PL90

Aplique / plafón
Wall lamp / ceiling lamp

5 x E-27 21 W
Bajo consumo
Energy saving



PLAFÓN
Resina glase
SOPORTE
Cristal tallado transparente

BODY
Glasse resin
CEILING SUPPORT
Transparent carved crystal



constanza



constanSSA

CERTIFICADO DE PRODUCTO ARTESANAL
HANDMADE PRODUCT CERTIFICATE

El modelo CONSTANSSA es una lámpara plafón fabricada artesanalmente con resina glaseada y procesos de producción totalmente manuales y de una en una, con numeración seriada lo cual significa que todas las luminarias son diferentes. De este modo pequeñas imperfecciones en el producto final consecuencia del trabajo manual no se consideran taras o faltas sino muestras de su carácter artesanal.

Así, habiendo informado de esto MODISS no aceptará ninguna reclamación basada en estos motivos.

CONSTANSSA is a wall and/or ceiling lamp made with Glasse resin, handcrafted and manufactured one by one with manual processes. This means that all the lamps are different and serially numbered. As a result of its manual process CONSTASSA may show little imperfections and/or bubbles that are not considered flaws or defects.

Having informed of these features, MODISS will not accept any claim for these reasons.

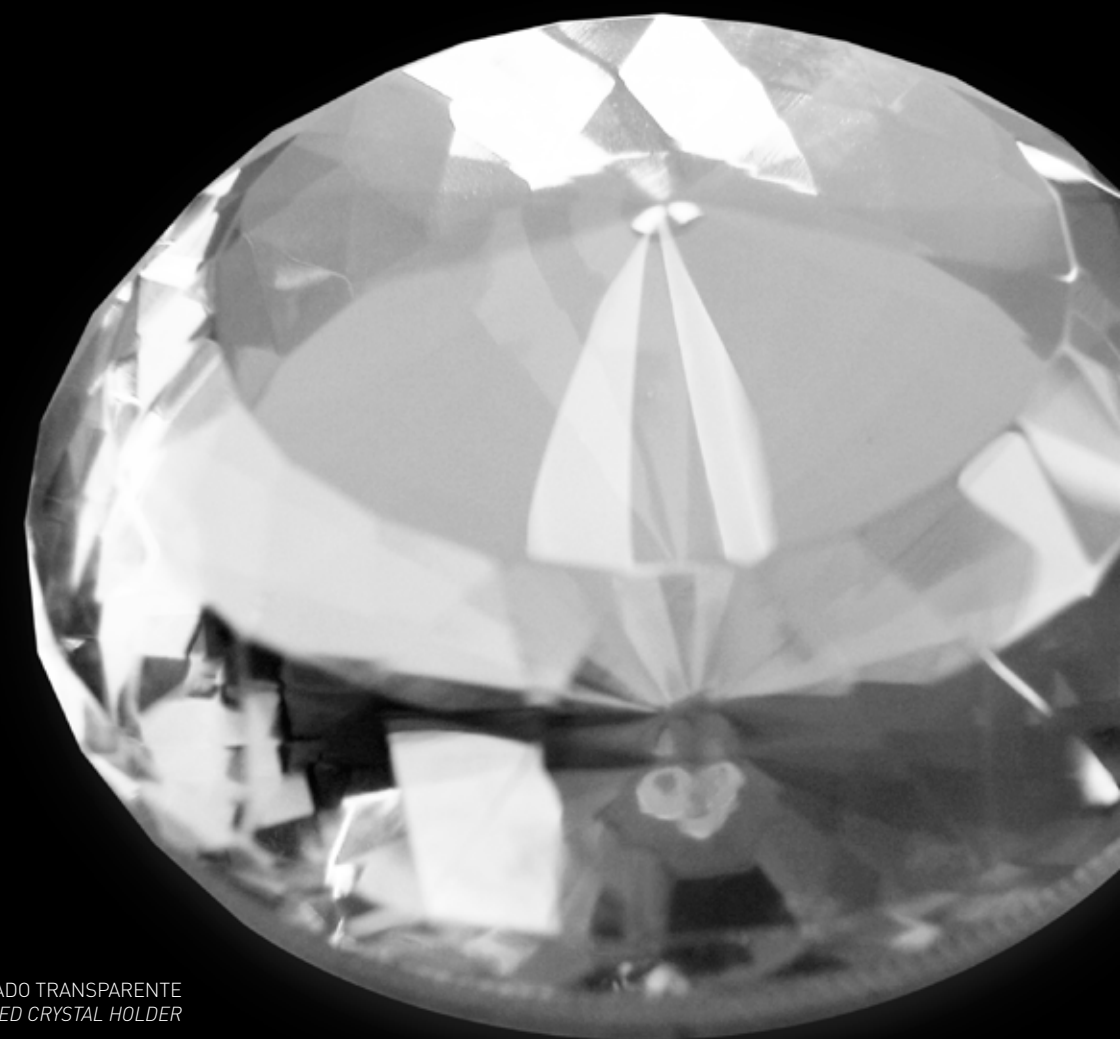

DETALLE SOPORTE CRISTAL TALLADO TRANSPARENTE
DETAIL TRANSPARENT CARVED CRYSTAL HOLDER

RE-
EDITION

COPENHAGUE

DESIGN:
MODISS DESIGN TEAM

Adoro la sobriedad siempre que tenga un toque de locura.
Siento debilidad por la combinación de opacidad con transparencia. Aspiro a fusionar modernidad con clasicismo... En una ciudad fría como Copenhague hallé calor para mis lámparas.
¿Qué es la vida sino una contradicción?

*I love sobriety as long as it has a touch of craziness about it.
I have a weakness for the combination of opacity and transparency. I aspire to merge modernity with classicism...
In the cold city of Copenhagen I found heat for my lights.
What is life but a contradiction?*

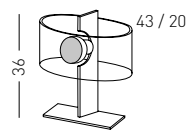

COPENHAGUE

Sobremesa
Table lamp

E-27 60 W



PANTALLA

Gris ahumado

METAL

Aluminio satinado

CABLE

Transparente

SHADE

Tinted grey

METAL

Satin aluminium

WIRE

Transparent

Filipo

DESIGN:
MODISS DESIGN TEAM

A menudo me recreo en la observación de la naturaleza. Es ésta una actividad muy grata y fructífera, en tanto en cuanto me abona la creatividad, la tierra donde siembro ideas relacionadas con la iluminación.

Sobre los planos trazo líneas orgánicas y desarrollo tendencias en evolución: el cristal llega a la plenitud, las bombillas sufren metamorfosis, los cables buscan la simbiosis con los pies... A veces escucho a Filippo y me parece oír su corazón.

I often stop and observe nature. It is a very gratifying and fruitful activity, as it feeds my creativity, the earth where I sow ideas related to illumination.

I draw organic lines on the plans and develop trends in evolution: glass comes to its plenitude, bulbs suffer a metamorphosis, cables look for a symbiosis with the feet... sometimes I listen to Filippo and I think I can hear his heart.

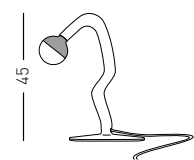

FILIPO 10

Sobremesa
Table lamp
E-27 60 W
Reflector decorativo cromo
Decorative chrome reflector



FILIPO 20

Sobremesa
Table lamp
E-27 60 W
Cúpula decorativa cromo
Decorative chrome crown



VIDRIO
Borosilicato
CABLE
Textil rojo

Pieza de CRISTAL SOPLADO ARTESANALMENTE
Variaciones estéticas sutiles (espesor, color, burbujas) forman parte de sus características.

GLASS
Borosilicate glass
WIRE
Red textile

HAND-MADE MOUTH-BLOWN GLASS piece.
Subtle aesthetical variations (thickness, colour, bubbles) are features of fine glass.



funghi

DESIGN:
MODISS DESIGN TEAM

Tomando un café con los ojos entornados para que la luz del sol no aparte ni por unos momentos mi vista del paisaje. Sentado frente a un bosque imaginario sueño que me pierdo en él y que sus criaturas me rodean. Recuerdo su aroma y aquí, en plena ciudad, mientras contemplo a Funghi todo vuelve a mi mente. Formas simples y perfectas, un reflejo de la esencia de la Naturaleza.

Enjoying a cup of coffee with my eyes half closed so the sunlight doesn't separate them from the landscape even for a moment. Sitting in front of an imaginary forest, I dream about losing myself there, surrounded by the woodland creatures. I remember its aroma and here, in the city, while contemplating Funghi, everything comes back to me. Simple and perfect shapes, reflecting the essence of Nature.

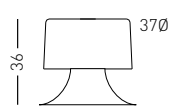
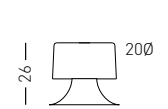
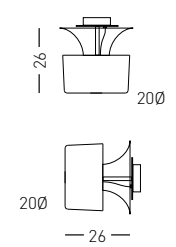

FUNGI 10	FUNGI 20	FUNGI 30	FUNGI 1AP10
Sobremesa Table lamp	Sobremesa Table lamp	Sobremesa Table lamp	Aplique / plafón Wall lamp / ceiling lamp
G-9 33 W	3 x G-9 20 W	3 x G-9 33 W	3 x G-9 33 W

PANTALLA Cristal opal blanco	SHADE White glass
METAL Cromo	METAL Chrome
PIE Metacrilato ahumado	BASE Tinte grey methacrylate

Gilda

DESIGN:
VALÉRY BOUVIER

Simplificando, Gilda ha pasado a la historia del cine por un guante y un guantazo.

¡Qué paradoja, en los tiempos que corren!

Para mi Gilda he buscado una línea sensual preñada de matices, ligera, esbelta y, sobre todo, blanca.

Honestamente, no me busquen entre quienes están del lado del guantazo.

To put it simply, Gilda has gone down in cinematic history because of a glove and a slap administered with it.

Something of a paradox in this day and age!

For my Gilda I looked for a sensual form full of nuances, light, svelte and above all white.

To be honest, you shouldn't expect to find me among those on the side of the slap.

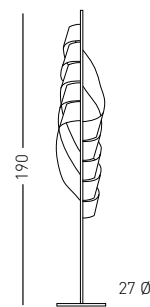

GILDA 60

Pie salón
Floor lamp

2 x E-14 42 W



GILDA 1C

Colgante individual
Single suspension
Peso / Weight 5,00 kg

2 x E-14 42 W



PANTALLA
Policarbonato opal blanco
METAL
Cromo satinado
CABLE
Transparente

SHADE
White polycarbonate
METAL
Satin chrome
WIRE
transparent

Gretta

DESIGN:
MODISS DESIGN TEAM

¿Podemos envolvernos en una mampara de cristal y aislarnos del mundo? Ella lo hizo, la gran Garbo se fabricó una imagen sensual, distante, enigmática. La belleza rodeada de un halo de misterio y fascinación. Así es Gretta, estilizada, hermosa, inalcanzable, un corazón de seda encerrado en un abrazo de cristal. Puro objeto de deseo.

Is it possible to be enveloped in a glass screen and be isolated from the world? She did it, the great Garbo created an image of herself that was sensual, distant and enigmatic. Beauty surrounded by a halo of mystery and fascination. That is how we can describe Gretta, stylish, beautiful, unattainable, a heart of silk enclosed in a glass embrace. A pure object of desire.

CRISTAL
Transparente
PANTALLA
Seda beige
Seda negra
METAL
Aluminio satinado
CABLE
Transparente

GLASS
Transparent
SHADE
Beige silk
Black silk
METAL
Satin aluminium
WIRE
Transparent

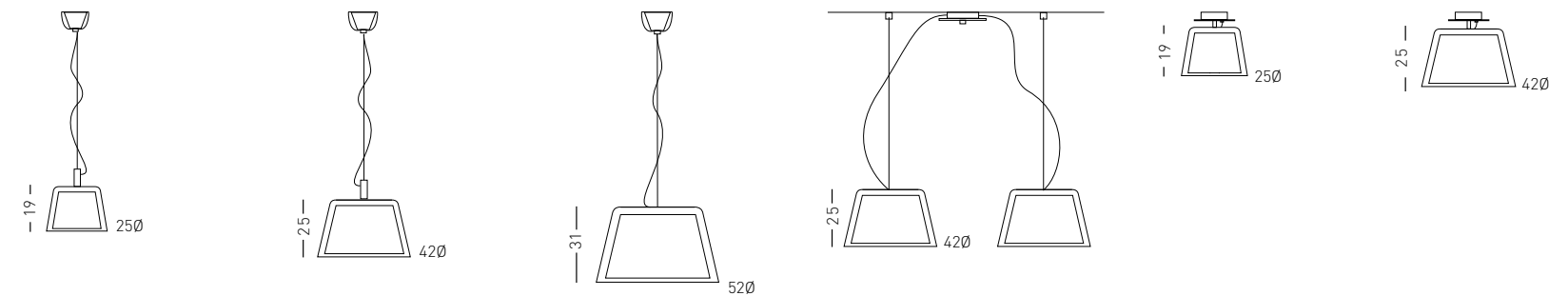
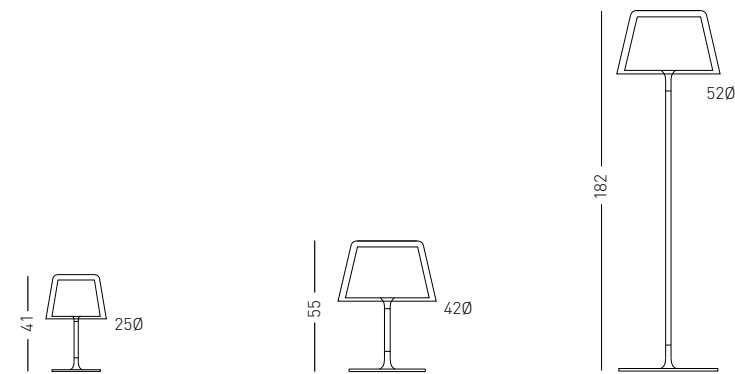

GRETTA 10	GRETTA 30	GRETTA 50
Sobremesa Table lamp	Sobremesa Table lamp	Pie salón Floor lamp
G-9 33 W	3 x G-9 33 W	3 x G-9 48 W

GRETTA 1S25	GRETTA 1S42	GRETTA 1S52	GRETTA 2S42	GRETTA 1W25	GRETTA 1W42
Colgante individual Single suspension Peso / Weight 7,50 kg	Colgante individual Single suspension Peso / Weight 9,00 kg.	Colgante individual Single suspension Peso / Weight 12,00 kg	Colgante doble Double suspension Peso / Weight 19,00 kg	Plafón Ceiling lamp	Plafón Ceiling lamp
E-14 7 / 11 W Bajo consumo Energy saving	E-27 15 / 20 W Bajo consumo Energy saving	E-27 20 / 25 W Bajo consumo Energy saving	2 x E-27 15 / 20 W Bajo consumo Energy saving	E-14 7 / 11 W Bajo consumo Energy saving	E-27 15 / 25 W Bajo consumo Energy saving



gretta



icaria

NEW

DESIGN:
MITJADOTZENA

Todo empezó con una explosión de luz, Icaria es el regreso al origen. Desde hace siglos hemos soñado con volar, perder toda noción de la realidad y flotar ingrávidos hacia otro mundo...como la luz, que en su estado más puro fluye libremente indómita e inalcanzable. Icaria nace de ese sueño, un amplificador lumínico y una mesita auxiliar. Dos cuerpos alejados por la unión de un destello... de una esencia. Un LED oculto se proyecta desde la base para brillar en otro elemento independiente sin uniones ni ataduras. Una simple idea y una ejecución exquisita.

Everything start with a big light explosion, Icaria is going back to the origin. Form the beginning of time we dream about flying, loose contact with reality floating on a non gravity space...as light in its purest form flows wild, free and unreachable. Icaria comes from that dream, a light amplifier together with an small table. Two separate objects linked by a flash... by an essence. A hidden LED projected from the base shines on an independent element without attachments or links. A simple idea with a superb execution.

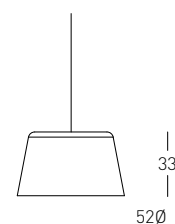

ICARIA

Pie salón
Floor lamp
Peso / Weight 12,00 kg
Mesa y pantalla iluminada
Table and ceiling shade lightening

LED 35 W - 700 mA



CRISTAL
Cristal arenado
BASE
Madera natural + Cristal arenado
CABLE
Transparente

GLASS
Sandblasted crystal glass
BASE
Natural wood + sandblasted natural wood
WIRE
Transparent









isabelina

DESIGN:
MODISS DESIGN TEAM

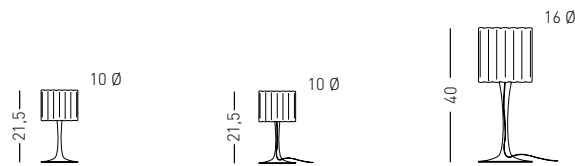
Los lugares con historia son motores del análisis, la imaginación y la creatividad. Quienes tengan la fortuna de conocer el monasterio de San Juan de los Reyes, en Toledo, comprenderán hasta qué punto el diseñador contuvo la respiración entre sus muros para admirar la belleza de los pilares, con toda su verticalidad, altura y serenidad. Recobrado el aliento, incluso el proyecto de una personal y sólida lámpara de vidrio borosilicato se había contagiado del estilo isabelino.

Places with history are a stimulus for analysis, imagination and creativity. Those who are fortunate enough to know the monastery of San Juan de los Reyes, in Toledo, will understand to what point the designer held his breath between its walls to admire the beauty of the pillars, with all their verticality, height and serenity. Recovering his breath, even the project of a personal and solid borosilicate glass lamp had been infected with the Elizabethan style.



ISABELINA 5	ISABELINA 10	ISABELINA 20
Candelabro Small candle	Sobremesa Table lamp	Sobremesa Table lamp
Vela pequeña Little candle	G-9 20 W	E-14 60 W Cúpula decorativa cromo Decorative chrome crown
		

VIDRIO
Borosilicato
CABLE
Transparente

GLASS
Borosilicate glass
WIRE
Transparent



ivanna

DESIGN:
MODISS DESIGN TEAM

Con la primera impresión nos vienen a la cabeza el péndulo de Foucault y aceleración de Coriolis producida por la rotación de la tierra. Una vez silenciada la ciencia, saltamos de la física a la metafísica y caemos suavemente en una desafiante síntesis de la verticalidad.

The first thing that comes to mind when we catch a glimpse of it is Foucault's Pendulum and the Coriolis effect created by the rotation of the earth. Once the voices of science fall silent, we leap from physics to metaphysics in a daring synthesis of verticality.

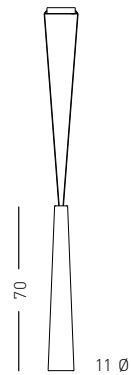

IVANNA 1C30

Colgante individual
Single suspension
Peso / Weight 3,00 kg

E-14 42 W



CRISTAL
Cristal laminado gris ahumado
METAL
Cromo brillo
CABLE
Transparente

GLASS
Smoky gray laminated glass
METAL
Chrome
WIRE
Transparent



Jade

DESIGN:
MODISS DESIGN TEAM

El jade es una piedra dura, brillante, usada en joyería por su extraña belleza.
Mi Jade también es así, firme, bella, un tanto indomable y, por encima de todo, luminosa... Me siento satisfecho de que, cuando cierro los ojos todas las noches, ella sea el último estímulo que recibe mi pupila.

Jade is a hard, shiny stone; used in jewellery for its strange beauty. My Jade is also like this, firm, beautiful, untameable and above all luminescent. I feel satisfied that when i close my eyes each night, she will be the last stimulus that my pupils receive.

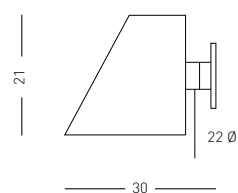

JADE

Aplique
Wall light

E-14 7 / 11 W
Bajo consumo
Energy saving



PANTALLA

Tela blanca
Tela cruda
Tela negra

METAL

Aluminio mate
Níquel satinado
Cromo

SHADE

White cloth
Beige cloth
Black cloth

METAL

Matt aluminium
Satin nickel
Chrome







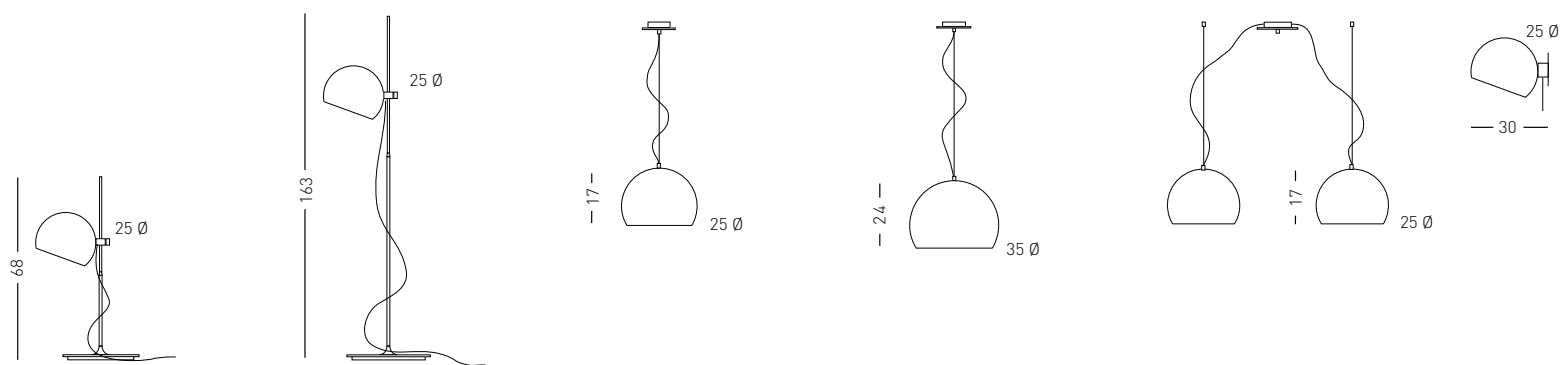

Joe

DESIGN:
JÓSEP SANCHO

El primer mandamiento del diseñador debería ser "La pieza creada cumplirá su misión con éxito". ¡Cuántas veces se ha cometido el pecado capital de convertir un objeto necesario en un utensilio completamente inútil amparándose en un supuesto valor estético! Modestamente, creo que Joe demuestra que forma y función pueden darse la mano en un contexto armónico.

The designer's first commandment ought to be: "The product you create shall successfully complete its mission". How many times has the capital sin of turning a necessary object into a completely useless utensil been committed in the name of some alleged aesthetic value! With all due modesty, I think that Joe shows how form and function can co-exist in harmony with one another.



JOE 30	JOE 60	JOE 1C25	JOE 1C35	JOE 2C25	JOE 1AP25
Sobremesa Table lamp	Pie salón Floor lamp	Colgante individual Single suspension Peso / Weight 2,00 kg	Colgante individual Single suspension Peso / Weight 2,50 kg	Colgante doble Double suspension Peso / Weight 3,00 kg	Aplique Wall light
E-27 15 / 20 W Bajo consumo Energy saving	E-27 15 / 20 W Bajo consumo Energy saving	E-27 15 / 20 W Bajo consumo Energy saving	E-27 15 / 20 W Bajo consumo Energy saving	2 x E-27 15 / 20 W Bajo consumo Energy saving	E-27 15 / 20 W Bajo consumo Energy saving
					



COMBINACIONES ENTRE ACABADOS
Metacrilato opal blanco con metal cromo satinado
Metacrilato negro con metal cromo brillo
CABLE
Transparente

FINISHES COMBINATIONS
White opal methacrylate with satin chrome metal
Black methacrylate with chrome metal
WIRE
Transparent

100

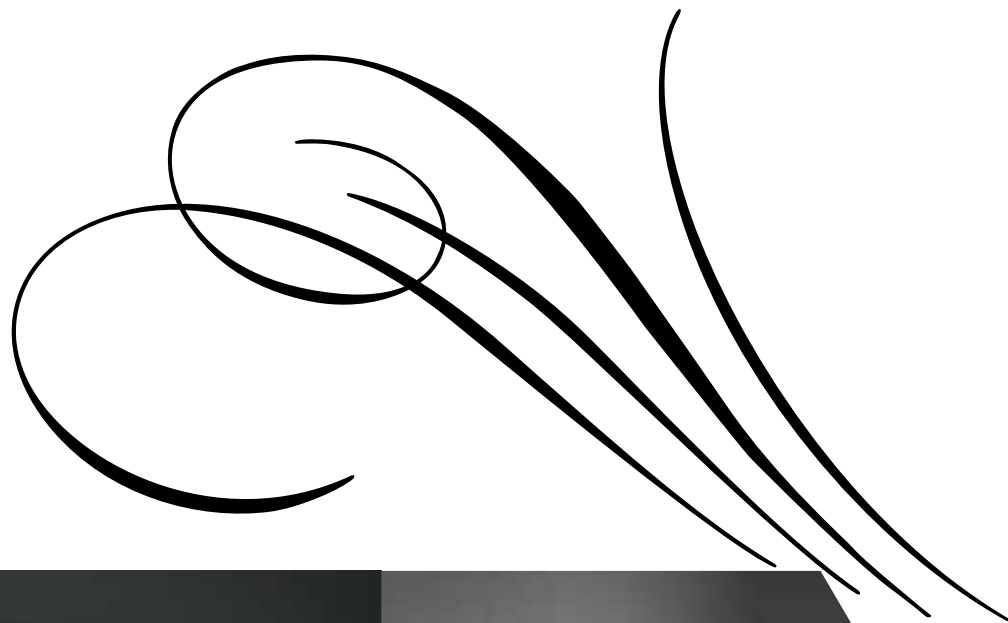

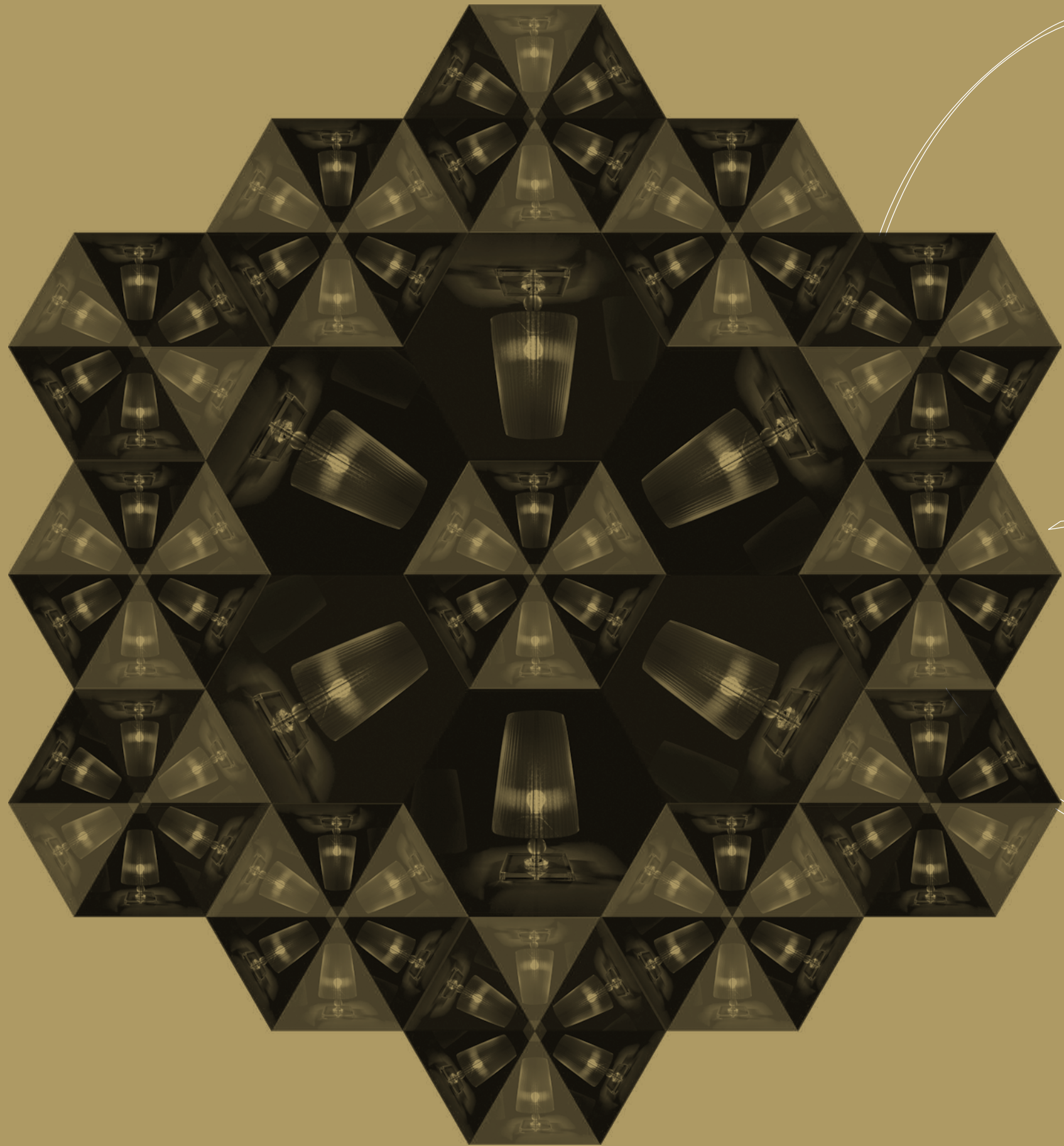

Julia



Julia

DESIGN:
MODISS DESIGN TEAM

Una base de cristal tallado envuelta en gasa, rodeada de magia y sensualidad. Vista al trasluz su alma rotunda se nos muestra como una hermosa mujer vestida para seducir.
Julia nos hace escapar suspiros... ¿qué esconde bajo ese ropaje que envuelve sin cubrir?...

*A cut-crystal base wrapped in gauze, surrounded by magic and sensuality. Seen against the light, its rounded soul looks like a beautiful woman dressed to seduce.
Julia makes you sigh... what might be hidden beneath that clothing, which envelops without covering?*

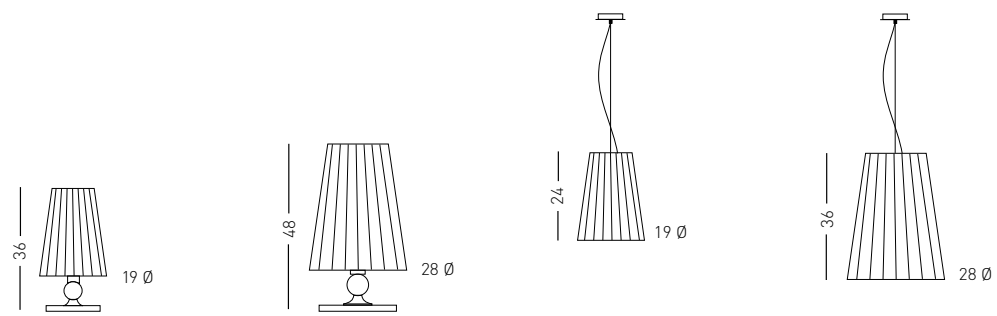

JULIA 10

JULIA 20

JULIA 1C10

JULIA 1C20

Sobremesa
Table lamp

Sobremesa
Table lamp

Colgante individual
Single suspension

Colgante individual
Single suspension

E-14 28 W

E-27 42 W
Regulador de luz
Intensity dimmer

E-14 28 W

E-27 42 W



PANTALLA

Gasa blanca / bola lima
Gasa negra / bola ahumada

BASE

Cristal tallado transparente

CABLE

Transparente

SHADE

White gauze / lime ball
Black gauze / tinted grey ball

BASE

Carved transparent crystal

WIRE

Transparent

kaikala

DESIGN:
LUIS PONS

Una catarata de lluvia y sol, un recuerdo de los amaneceres de la Florida natal ha inspirado a este joven diseñador de Miami. Así es Kaikala una sonrisa cómplice, un guiño de metal y metacrilato. Una cascada de buen "feeling" que despierta en nosotros el anhelo de ser atrevidos y por qué no, cavalgar las olas!

A cascade of rain and sun, a reminiscence of sunrises in his Florida birthplace inspired this young designer from Miami. This is how we can describe Kaikala, the smile of a fan accomplice, a knowing wink of metal and methacrylate. A torrent of good feeling that awakens the desire to be daring and even to ride the waves!

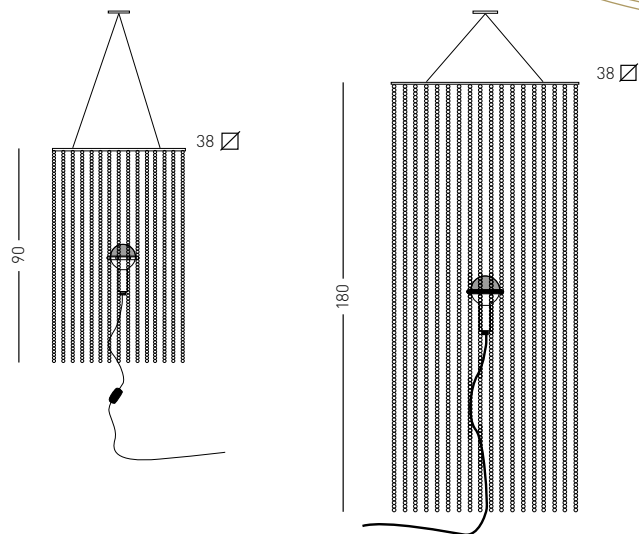

KAIKALA 30

Pie salón / colgante
Floor lamp / suspension
Peso / Weight 11,00 kg

E-27 150 W
Cúpula decorativa cromo
Decorative chrome crown



KAIKALA 60

Pie salón / colgante
Floor lamp / suspension
Peso / Weight 14,00 kg

E-27 150 W
Cúpula decorativa cromo
Decorative chrome crown



SOPORTE

Metacrilato espejo

CADENAS

Tira de bolas metálicas

SUPPORT

Mirror methacrylate

CHAINS

Strip of metal balls

Kaikala

DETALLE ARO IMANTADO QUE SOSTIENE LA FUENTE DE LUZ. PERMITE AJUSTAR A DIFERENTES ALTURAS
MAGNETIZED RING WHICH HOLDS THE LAMP. IT ALLOWS TO UP AND / OR DOWN THE LIGHT AT DIFFERENT HEIGHTS

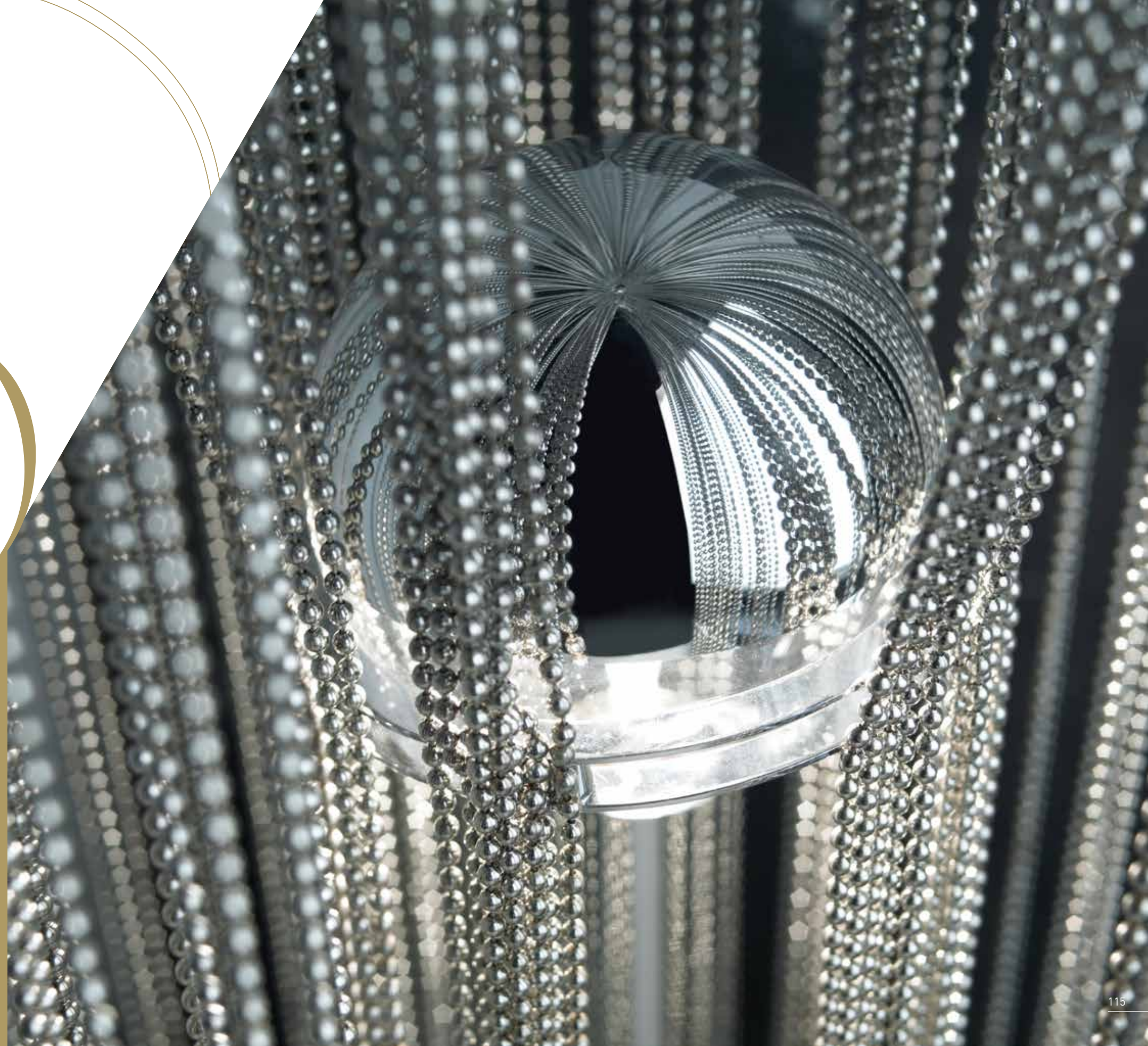

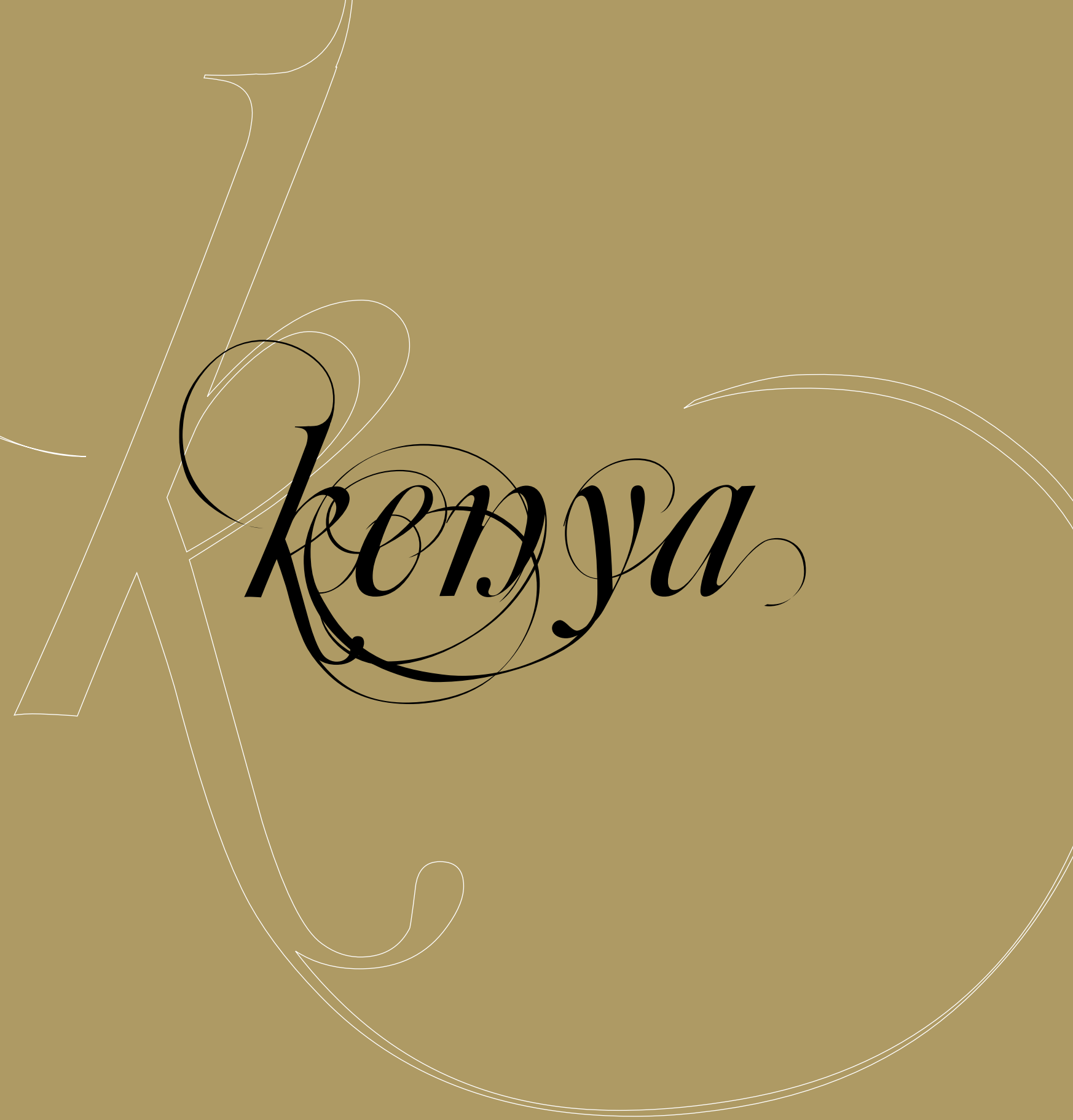
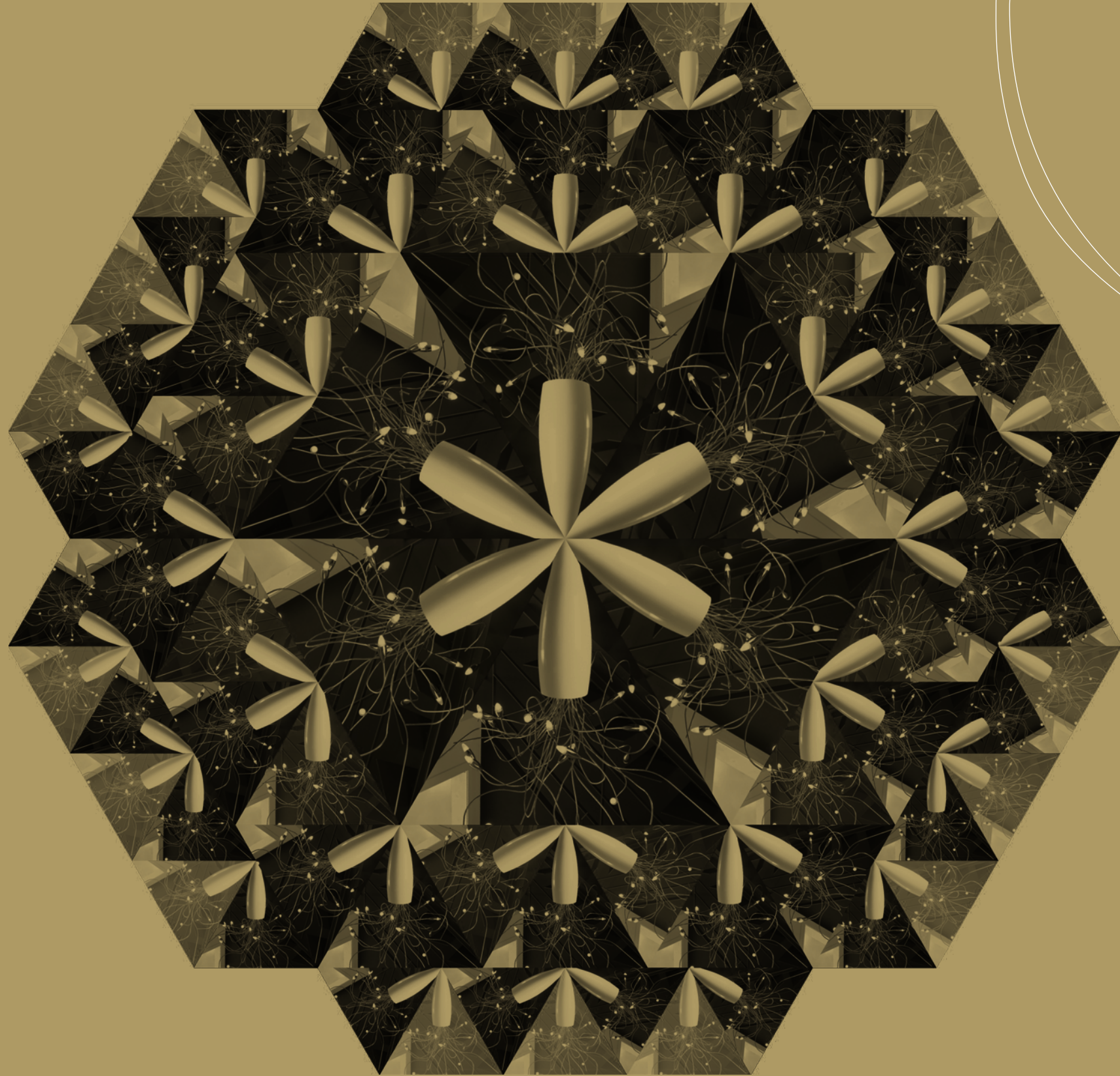

Kenya

DESIGN:
MODISS DESIGN TEAM

Ya la escritora danesa Karen von Blixen se enamoró antes que nosotros de este país exótico, sorprendente, lleno de magia, luz y color que es Kenya. A él le dedicó sus sentidas "Memorias de África". Nosotros hemos querido hacer nuestro propio homenaje y hemos creado esta vibrante, alegre, atrevida y esbelta fuente de luz. No sientes como redoblan los tambores?

The Danish writer Karen von Blixen fell in love with this exotic country long before we did. Kenya is a surprising place, full of magic, light and colour. Her novel "Out of Africa" was dedicated to Kenya. We wish to offer our own tribute by creating this vibrant, vivacious, daring and slender light source. Can't you feel the beats of the drums?

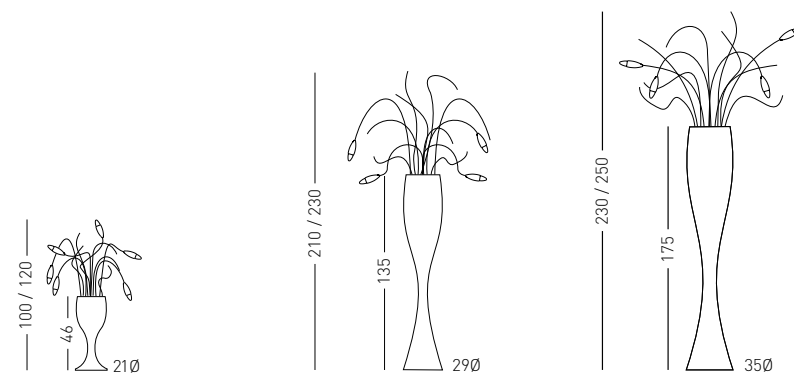

KENYA 30

Sobremesa
Table lamp

10 x E-14 28 W



KENYA 50

Pie salón
Floor lamp

14 x E-14 28 W



KENYA 60

Pie salón
Floor lamp

18 x E-14 28 W



CUERPO

Fibra de vidrio lacado blanco brillo
Fibra de vidrio lacado negro brillo
Fibra de vidrio lacado laminado plata
Fibra de vidrio lacado laminado oro

METAL

Cromo mate
Oro mate

CLABLE

Transparente

BODY

White lacquered fiber glass
Black lacquered fiber glass
Silver lacquered laminated fiber glass
Gold lacquered laminated fiber glass

METAL

Matt chrome
Matt gold

WIRE

Transparent



Kenya



DESIGN:
MODISS DESIGN TEAM

Loe black

Los mecanismos de la creación funcionan misteriosamente. A veces, un torrente de imágenes y sensaciones sin sentido adquieren de pronto coherencia y surge del caos una emocionante armonía: Loe Black. Ella es el fruto de una mágica alucinación y la prueba de que un diseño también puede nacer de un sueño.

The mechanisms of creation work in mysterious ways. Sometimes a flood of images and hazy sensations soon take on a coherent shape and from the chaos an emotional harmony emerges: Loe Black. Fruit of a magical hallucination and proof that a design can also be born from a dream.

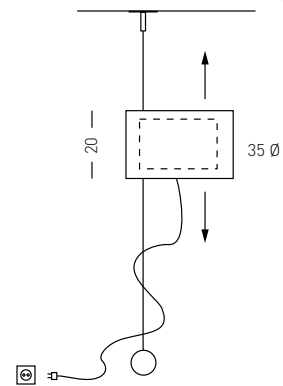

LOE BLACK

Pie salón / colgante
Floor lamp / suspension
Peso / Weight 3,50 kg

E-27 52 W



PANTALLA
EXTERIOR: Organza negra
INTERIOR: Pergamino poliéster blanco
METAL
Cromo brillo
CABLE
Textil negro

SHADE
OUTER: Black organza cloth
INTERIOR: White polyester parchment
METAL
Bright chrome
WIRE
Black textile



Loe classic

DESIGN:
MODISS DESIGN TEAM

El equilibrio no siempre es fácil. En esta ocasión necesité la ayuda de un contrapeso para que Loe flotara en el aire. Es raro, lo sé. No es corriente que una lámpara "de pie" no sólo no tenga pie, sino que además se sujete en el techo. Pero, a estas alturas, ¿quién no desea apartarse de lo corriente, de la corriente?

Finding equilibrium is not always easy. On the occasion I needed the help of a counter-balance so that Loe En could float in the air. It is strange, I know. It is not common that a standard lamp not only does not stand but is fixed to the ceiling. But at the end of the day, who does not wish to break with the norm?

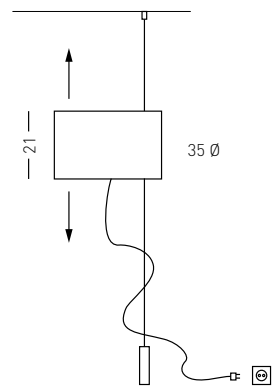

LOE CLASSIC

Pie salón / colgante
Floor lamp / suspension
Peso / Weight 3,50 kg.

E-27 52 W



PANTALLA
Malla blanca
Rafia blanca
METAL
Aluminio mate
CABLE
Negro

SHADE
White mesh
White raffia
METAL
Matt aluminium
WIRE
Black



Lopo

DESIGN:
MODISS DESIGN TEAM

Cualquier objeto merecedor de formar parte de un hogar debería estar dotado de alma. Algo tan trivial a priori como una lámpara puede llegar a hablar de nosotros y para nosotros si, efectivamente, posee esta cualidad. Quizá el mejor ejemplo de esta afirmación sea Lopo, con su pantalla de lino, invitándonos a una existencia plácida.

Any object worthy of being in a home must have a soul. Something so trivial at first sight as a light can come to say things about us and for us if it really does possess this quality. Perhaps the best example of this assertion is Lopo, which with its linen shade invites us to lead a placid life.

PANTALLA SUPERIOR
Tela lino tierra
Tela negra
PANTALLA INFERIOR
Tela blanca
CABLE
Transparente

UPPER SHADE
Land linen cloth
Black cloth
LOWER SHADE
White cloth
WIRE
Transparent

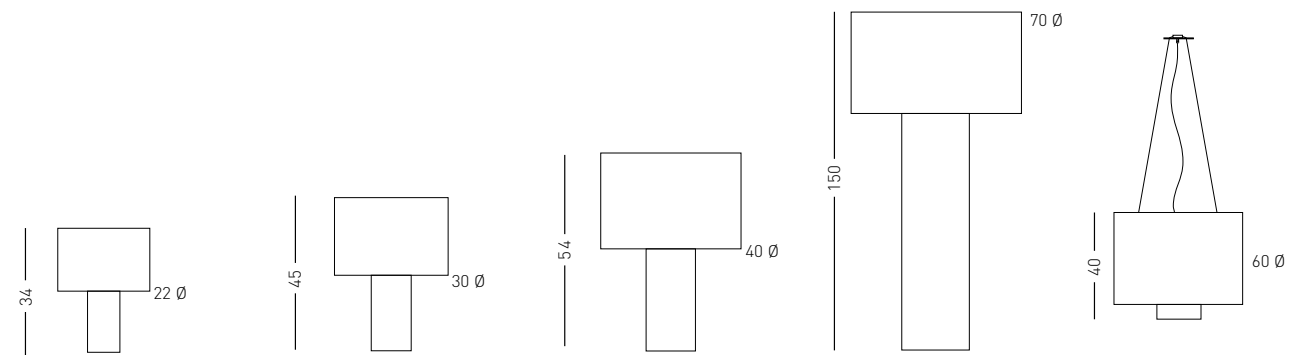
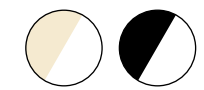

LOPO 10	LOPO 20	LOPO 30	LOPO 60	LOPO 1C60
Sobremesa Table lamp	Sobremesa Table lamp	Sobremesa Table lamp	Pie salón Floor lamp	Colgante individual Single suspension Peso / Weight 4,50 kg.
1 x E-27 42 W 1 x E-14 28 W	2 x E-27 42 W	2 x E-27 42 W	3 x E-27 52 W	5 x E-27 42 W

Luccas

DESIGN:
RAMÓN BENEDITO

Ramón Benedito es un gran diseñador y, además, un inconformista. Quizá lo uno sea consecuencia de lo otro. No sé. Tampoco sé en qué orden aparecen las buenas ideas en su cabeza ni cómo consigue combinarlas con tanto ingenio. La próxima vez que tomemos un café me tendrá que decir si Luccas es una luz de acento con una vertiente ambiental o un aplique decorativo con un led de uso focalizado. Hasta que llegue ese momento, me gustan sus interrogantes.

Ramón Benedito is a great designer as well as a non-conformist. Perhaps one thing is the consequence of the other. I do not know. Neither do I know the order in which the good ideas come to his head or how he manages to combine them so ingeniously. Next time we have a coffee together, he will have to tell me whether Luccas is an accent light with an atmospheric side or a decorative light fitting with a spotlight led. Until that moment arrives, I like the questions he provokes.

LED

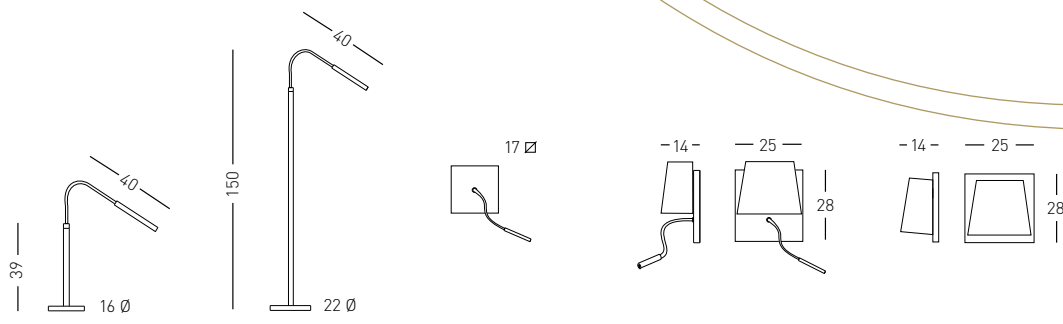

LUCCAS 10	LUCCAS 50	LUCCAS AP10	LUCCAS AP20	LUCCAS AP25
Sobremesa Table lamp	Pie salón Floor lamp	Aplique Wall lamp	Aplique Wall lamp	Aplique Wall lamp
LED 3 W-700 mA	LED 3 W-700 mA	LED 3 W-700 mA	LED 3 W-700 mA G-9 48 W	G-9 48 W

METAL
Aluminio satinado
Cromo
CRISTAL
Opal blanco AP20-AP25
Opal negro AP20-AP25

METAL
Satin aluminium
Chrome
GLASS
White glass AP20-AP25
Black glass AP20-AP25



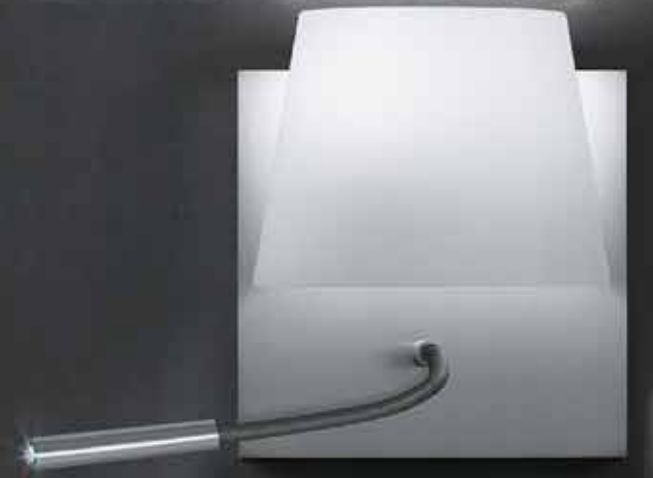

LED

NEW

margarita

DESIGN:
NADIA CORSARO & MARCELO DABINI

Abarca tus espacios a plena luz del día y persiste con elegancia en la penumbra de la noche. Una flor que escucha y sabe recordar, pues de ella se dice que representa los pensamientos de los amigos ausentes. Su diseño sostenible revive el alma y la belleza de las flores que lucen en la naturaleza para convertir tu entorno en un lugar único.

Una experiencia sensorial. Mima sus aros. Acaricia sus pétalos. Dales forma con ternura. Observa como florece su hermosura...

Cada uno de sus pétalos está elaborado con maderas recicladas que contribuyen a evitar la tala masiva de árboles y garantizar la disponibilidad de este recurso en el futuro.

Span your spaces in broad daylight and persist with elegance in the semi-darkness of the night. A flower that listens to you and can remember, it is said it represents the absent friends thoughts.

Born to be beautiful. The soul and beauty of the natural flowers inspired us its design. It transforms any space in an unique place.

Pamper its rings. Caress its petals and shape them with tenderness. Enjoy how its beauty blows...

Each one of its petals is made of recycled wood which contributes to avoid the massive tree felling assuring the future availability of this natural source.

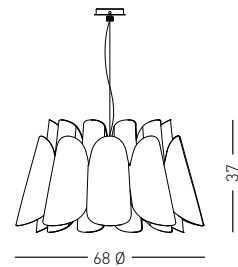

MARGARITA 1C60

Colgante individual
Single suspension
Peso / Weight 2,5 kg

LED E-27 10 W
(Recomendado / Recommended)



PANTALLA
Chapa de madera reconstituida
Natural
Tabacco

CABLE
Negro

SHADE
Reconstitued wood veneer
Natural
Tabacco

WIRE
Black



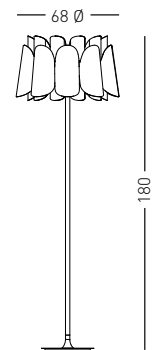

MARGARITA 60

Pie salón
Floor lamp

LED E-27 10 W
(Recomendado / Recommended)



PANTALLA
Chapa de madera
reconstituída
Natural
Tabaco
CABLE
Negro
BASE
Negra

SHADE
Reconstituted wood
veneer
Natural
Tabacco
WIRE
Black
BASE
Black



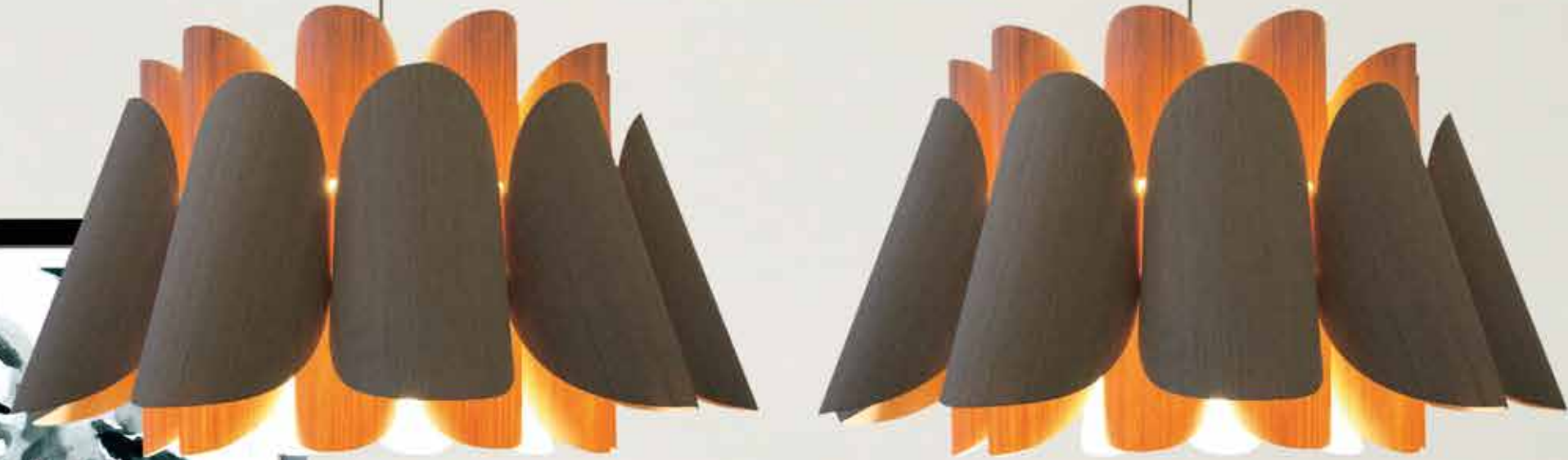

maria

DESIGN:
MODISS DESIGN TEAM



"Maria, I've just met a girl named Maria!"
Con West Side Story, el género toma una nueva dirección: la crítica social.
También la serie Maria es pionera: marca la tendencia del diseño cúbico en la realización de las pantallas.
¿Había un nombre mejor?

"Maria, I've just met a girl named Maria!"
With West Side Story, the genre takes a new direction: the social critic.
The Maria series is also a pioneer: beginning a trend of cubic design in the creation of the shade.
Could there be a better name?

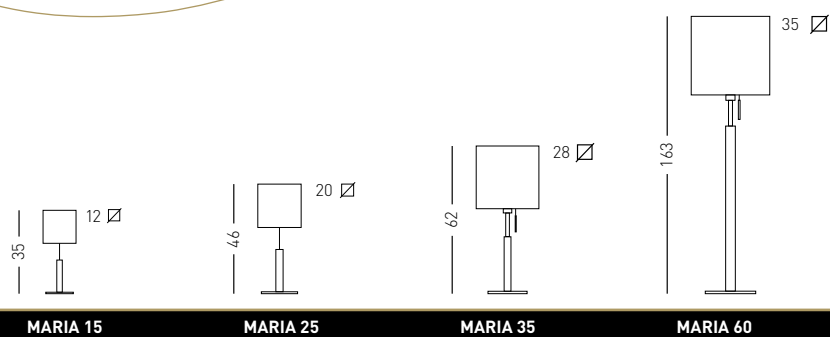

MARIA 15	MARIA 25	MARIA 35	MARIA 60
Sobremesa Table lamp	Sobremesa Table lamp	Sobremesa Table lamp	Pie salón Floor lamp
E-14 7 / 9 W Bajo consumo Energy saving	E-27 7 / 11 W Bajo consumo Energy saving	E-27 15 / 25 W Bajo consumo Energy saving	E-27 20 / 25 W Bajo consumo Energy saving

PANTALLA
Tela blanca
Tela cruda
MADERA
Lacado blanco
Wenge
METAL
Aluminio mate
CABLE
Transparente

SHADE
White cloth
Beige cloth
WOOD
White lacquered
Wenge
METAL
Matt aluminium
WIRE
Transparent



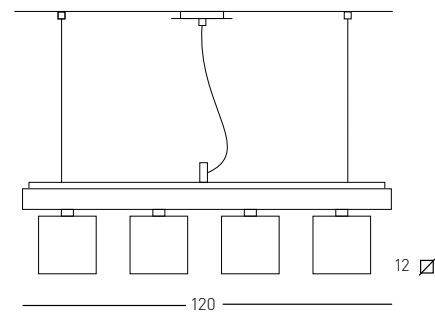
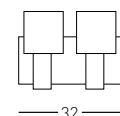
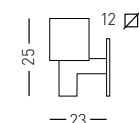
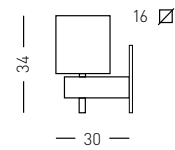
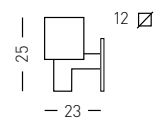
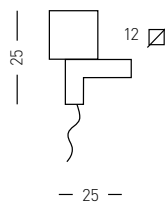

MARIA 1AP12

MARIA 1AP16

MARIA 2AP12

MARIA 4L12

MARIA 5

Colgante cuádruple
Quadruple suspension
Peso / Weight 6,50 kg.

Aplique
Wall lamp

Aplique
Wall lamp

Colgante cuádruple
Quadruple suspension
Peso / Weight 6,50 kg.

Aplique
Wall lamp

4 x E-14 7 / 9 W
Bajo consumo
Energy saving

E-27 11 / 15 W
Bajo consumo
Energy saving

2 x E-14 7 / 9 W
Bajo consumo
Energy saving

4 x E-14 7 / 9 W
Bajo consumo
Energy saving

E-14 7 / 9 W
Bajo consumo
Energy saving



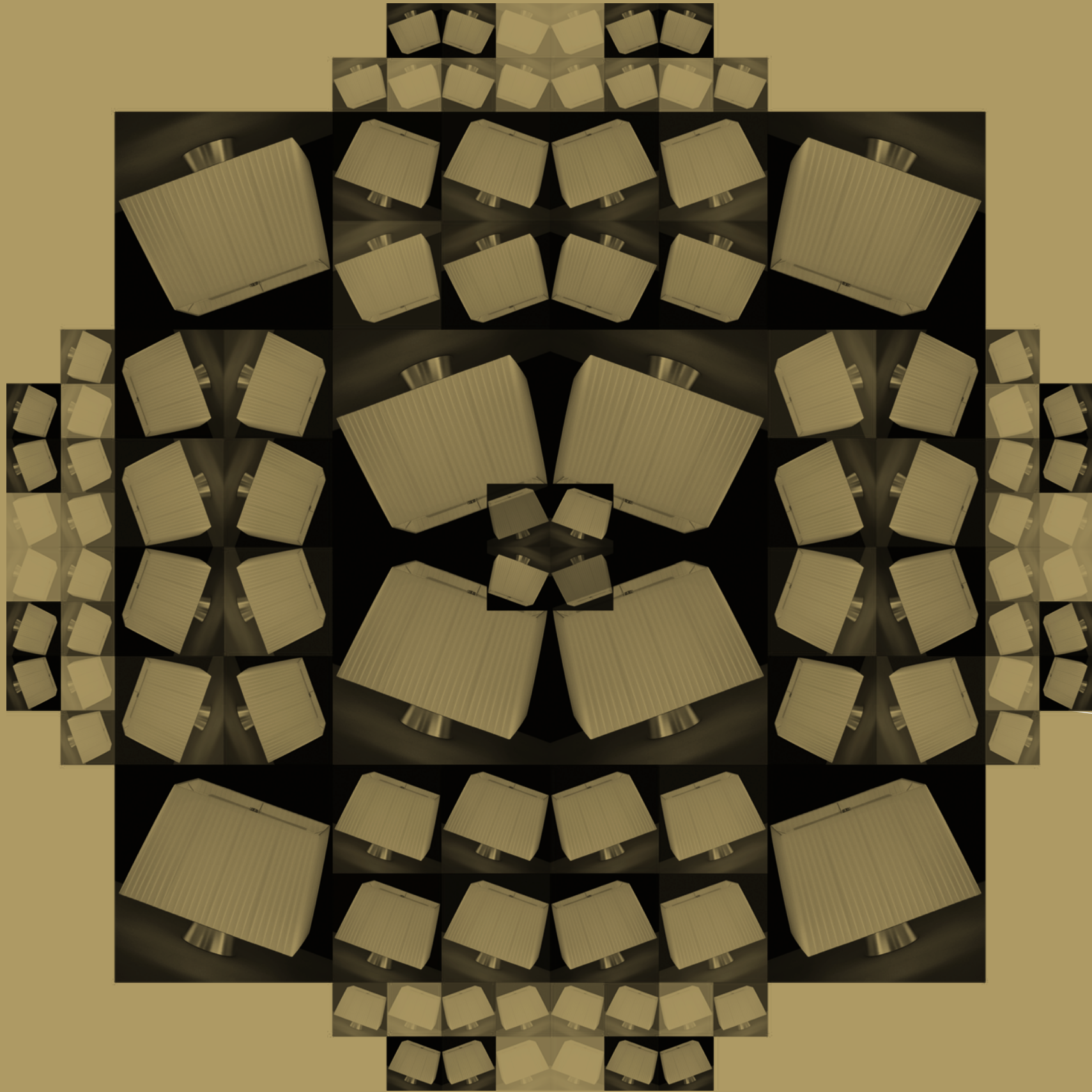

Martina

martina

DESIGN:
MODISS DESIGN TEAM

Un libro de arte que cayó a mis manos sentenciaba: "elegancia se materializa en líneas curvas y colores cálidos". Si hay algo que odio es la doctrina del "porque sí", de modo que me propuse crear una lámpara angular, fría y, a la vez, exquisita. El escritor, de cuyo nombre no quiero acordarme, nunca recibirá una muestra.

A book that fell into my hands declared "elegance is created in curved lines and hot colours". If there is something I hate it is the doctrine of "because I say so", this led me to create an angular, cold, yet exquisite lamp. The author, whose name I don't want to remember, will never receive a sample!

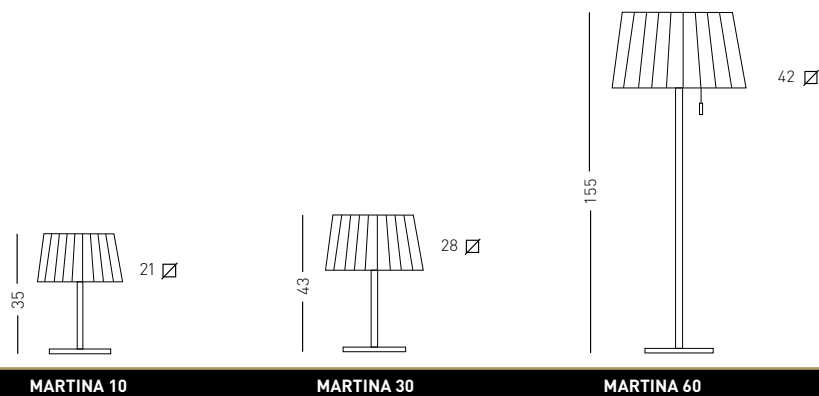

MARTINA 10	MARTINA 30	MARTINA 60
Sobremesa Table lamp	Sobremesa Table lamp	Pie salón Floor lamp
E-27 11 / 15 W Bajo consumo Energy saving	E-27 15 / 25 W Bajo consumo Energy saving	2 x E-27 15 / 25 W Bajo consumo Energy saving

NEW
MATERIAL

PANTALLA
Cinta seda blanca / Cinta seda negra
Cinta seda roja

METAL
Níquel satinado

CABLE
Transparente

SHADE
White silk strip / Black silk strip
Red silk strip

METAL
Satin nickel

WIRE
Transparent



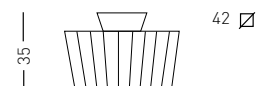
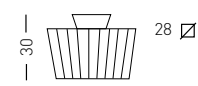

MARTINA 1P28

Plafón
Ceiling lamp

E-27 15 / 25 W
Bajo consumo
Energy saving



MARTINA 1P42

Plafón
Ceiling lamp

E-27 15 / 25 W
Bajo consumo
Energy saving



medusa

DESIGN:
MODISS DESIGN TEAM

Su sangre resucitaba a los muertos y su cabeza, que convertía en piedra a quien la miraba, permitió a Perseo huir con su amada Andrómaca... ¡No está mal para un monstruo marino, con la cabeza poblada de serpientes en lugar de pelo!
Desde hace siglos su cabeza reposa en el escudo de Atenea y, desde hace algún tiempo, su tela sobre mi mesa.

*Her blood resuscitated the dead and her head turned those who looked at her to stone. She permitted Perseo to flee with his love Andrómaca... Not bad for a sea monster, with a head crowded with snakes instead of hair!
For centuries her head has rested on Athena's shield and, for some time, her cloth is above my table.*

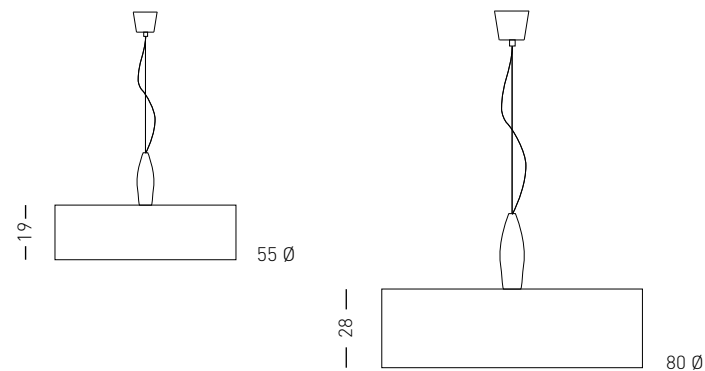

PANTALLA
Plisado crema
Tela blanca
Tela negra
DIFUSOR
Glasé ácido
METAL
Aluminio satinado
CABLE
Transparente

SHADE
Pleated cream
White cloth
Black cloth
GLASS DIFFUSER
Frosted glass
METAL
Satin aluminium
WIRE
Transparent



MEDUSA 1C50

Colgante individual
Single suspension
Peso / Weight 6,00 kg

2 x E-27 52 W



MEDUSA 1C80

Colgante individual
Single suspension
Peso / Weight 10,00 kg

2 x E-27 70 W



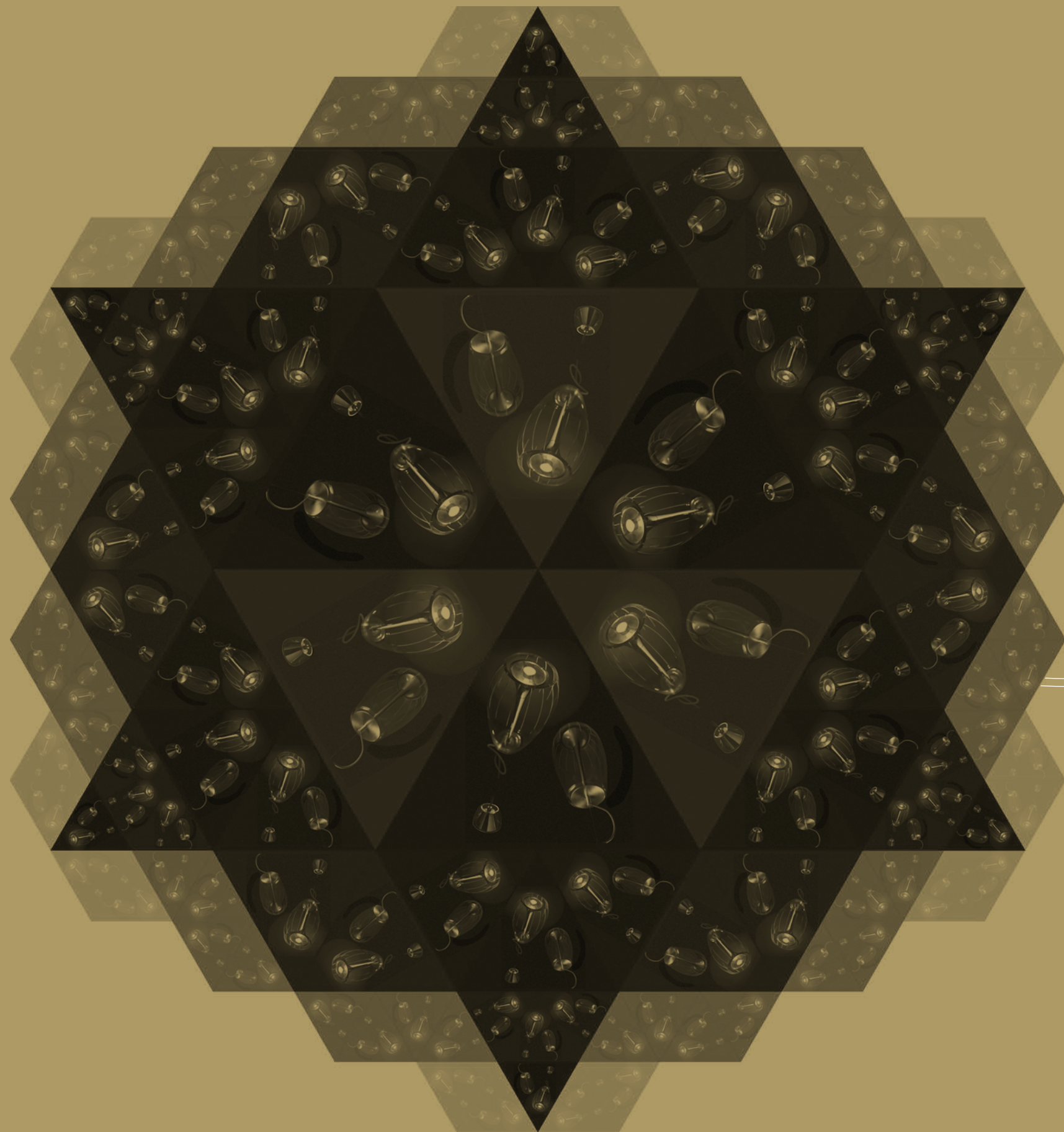

Miles

Miles

DESIGN:
MODISS DESIGN TEAM

Un escenario en penumbra en la costa oeste americana, son los años 50 y la voz de Ella Fitzgerald "llora" un tema mientras la trompeta de Miles Davis la toma de la mano y la eleva hasta donde sólo los grandes genios pueden llegar. Y al abrir los ojos sabemos que estamos en casa pero que gracias a nuestro Miles, esta pieza con alma de metal en forma de trompeta y cuerpo de cristal, nos hemos transportado a ese mundo mágico que habita en nuestra imaginación.

A half-lit stage on the American west coast, it is the 1950s and Ella Fitzgerald's voice "weeps" a song while Miles Davis' trumpet accompanies her, elevating the song to heights that only the great can reach. And when you open your eyes you know you are at home, but thanks to our Miles, a lamp with a heart of trumpet-shaped metal and body of glass, you have been transported to the magical world of your imagination.

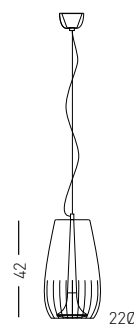

MILES 1C

Colgante individual
Single suspension
Peso / Weight 4,50 kg

GU-10 75 W



PANTALLA
Cristal tallado transparente
METAL
Cromo brillo
Oro satinado
CABLE
Textil rojo

SHADE
Carved transparent crystal
METAL
Shiny chrome
Satin gold
WIRE
Red textil





monna

DESIGN:
MODISS DESIGN TEAM

El pan de oro con el que recubrieron los techos de sus palacios reyes y príncipes, interviene aquí como invitado de excepción, para dotar a una lámpara de carácter en su perfecta imitación de la brillante imperfección de las texturas, siempre fascinantes, de la naturaleza.

The gold leaf with which kings and princes once covered their palace ceilings appears here as a guest of honour to give a lamp a distinguished character in perfect imitation of the brilliant imperfection of the ever-fascinating textures of nature.

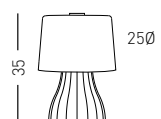

MONNA

Sobremesa
Table lamp

G-9 48 W



CRISTAL PANTALLA

Pan de oro dorado
Pan de oro plateado

CRISTAL BASE

Borosilicato rayado

GLASS SHADE

Gold leaf

Silver leaf

GLASS BASE

Bordered borosilicate

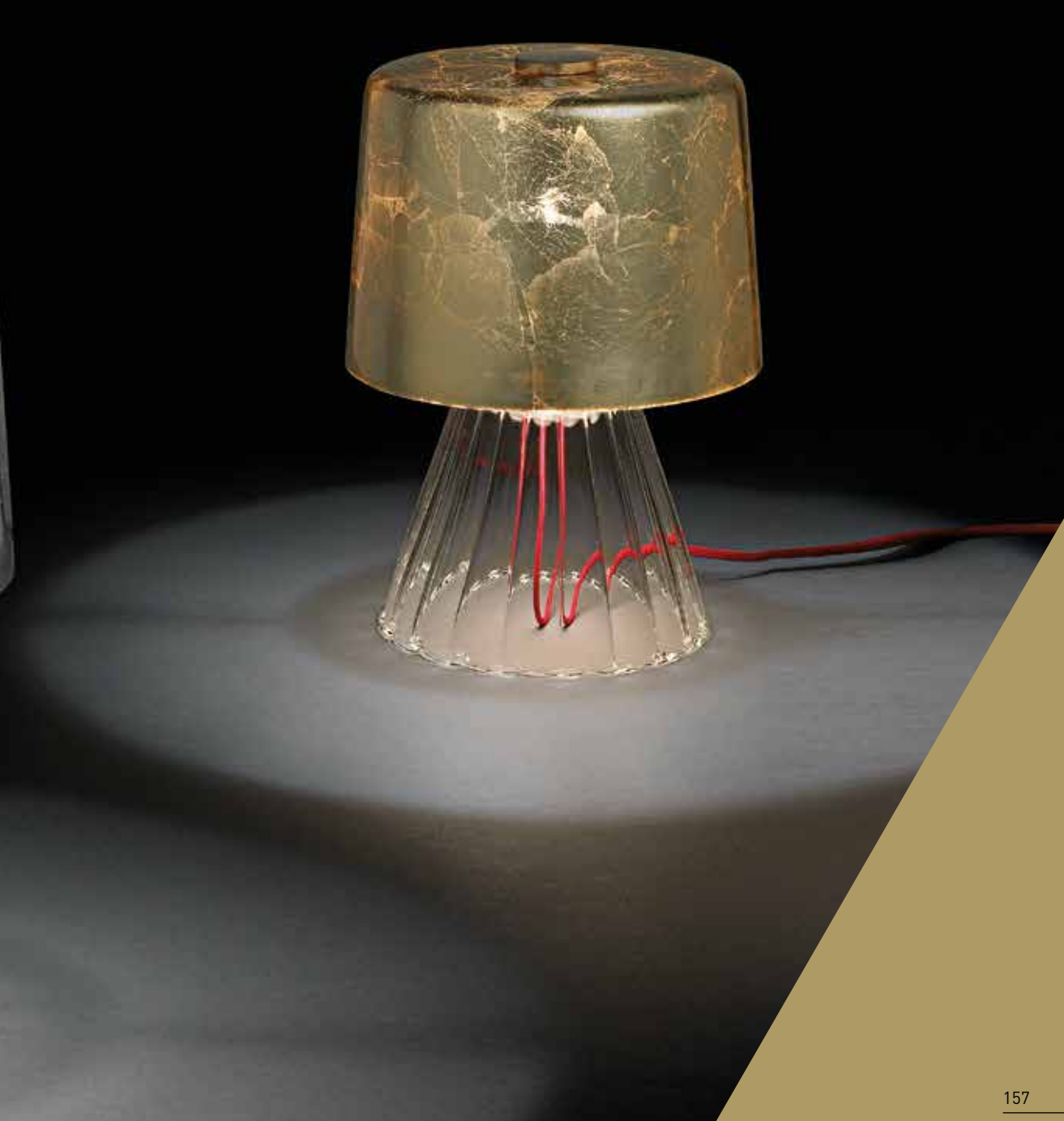

MOSSI

DESIGN:
MODISS DESIGN TEAM

Al primero que dijo "quedan unos flecos por resolver del contrato" se le hubiera tenido que petrificar la lengua, como si de un castigo divino se tratara. Porque, al fin y al cabo, mezclar un concepto tan sensual con los negocios es casi una herejía, ¿no cree?
Si usted comparte mi opinión le gustará Mossi, este sofisticado fleco, despeinado y brillante, de bolas de cristal y detalles de Strass® Swarovski® crystal. Un icono hipnótico y refinado para quienes nos dejamos seducir por los mantones de Manila, el cabaret e incluso las ramas de los sauces acunadas por la brisa.

*The first person that said, "there are some loose ends in the contract" should have had his tongue petrified, like a divine punishment. Because, in the end, to mix such a sensual concept with business is almost heresy, don't you think?
If you agree with me, you will like, this sophisticated fringe, uncombed and brilliant, with glass balls and Strass® Swarovski® crystal colour details. A hypnotic and refined icon for those who are seduced by embroidered shawls, cabaret and even the branches of willows swaying in the wind.*

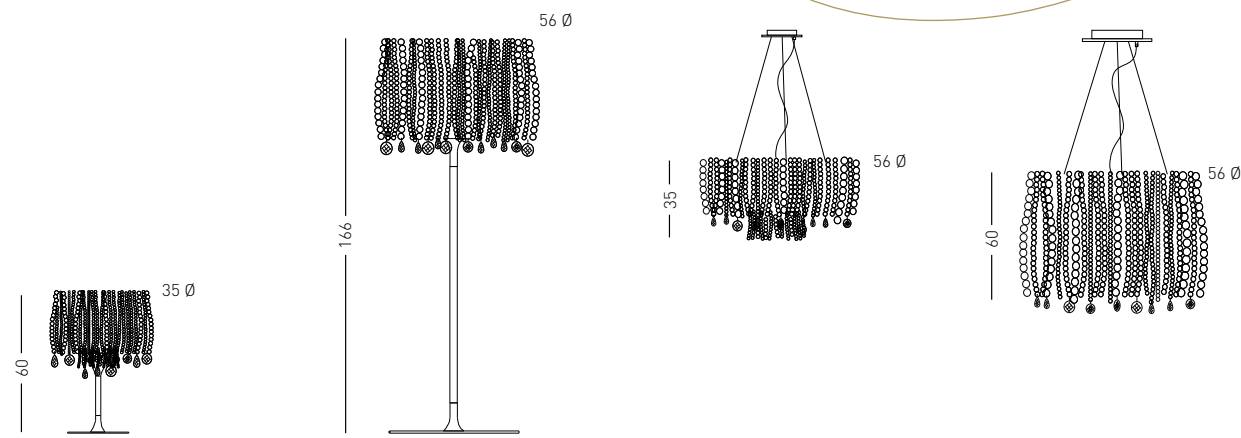

MOSSI 30	MOSSI 50	MOSSI 1C50	MOSSI 1C60
Sobremesa Table lamp	Pie salón Floor lamp	Colgante individual Single suspension Peso / Weight 18,50 kg	Colgante individual Single suspension Peso / Weight 24,00 kg
3 x E-14 42 W	3 x E-27 60 / 100 W	3 x E-27 60 / 100 W 1 x GU-10 75 W	4 x E-27 60 / 100 W

MADE WITH SWAROVSKI® ELEMENTS
HECHO CON SWAROVSKI® ELEMENTS

PANTALLA
Bolas de cristal
El cristal de color es de
Strass® Swarovski®
crystal
METAL
cromo
CABLE
transparente

SHADE
Glass balls
The crystal colour is Strass®
Swarovski® crystal
METAL
Chrome
WIRE
Transparent



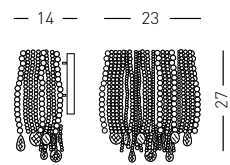

MOSSI 1AP23

Aplique
Wall lamp

E-14 42 W

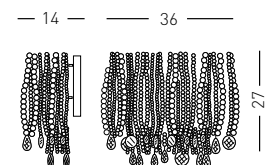

MOSSI AP36

Aplique
Wall lamp

2 x E-14 28 W



natali

DESIGN:
MODISS DESIGN TEAM

Desde hace años soy un férreo defensor de la iluminación ambiental. Exactamente desde 1985, cuando, al anochecer, sentado en una mesa anodina, con Brothers in Arms girando en el plato y la mujer más bella de la tierra compartiendo cena frente a mí ¡¡alguien encendió una bombilla de 200 W!!

No se que pasó
pero fue más rápido que un parpadeo.

From exactly 1985 I have been a convinced defensor of soft lighting. I was sitting at a dull table, with Brothers in Arms playing on the turntable, sharing supper with the most beautiful woman in the world when somebody switched on a 200 W lightbulb!!

*I don't know how it happened
but it was faster than the eye could flick.*

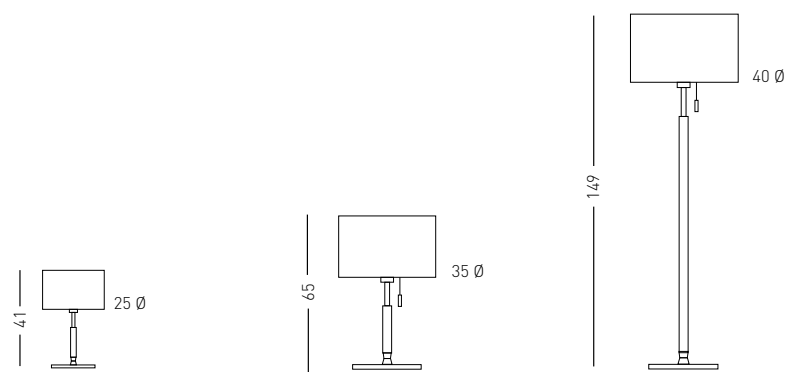

NATALI 10

Sobremesa
Table lamp

E-27 11 / 15 W
Bajo consumo
Energy saving



NATALI 30

Sobremesa
Table lamp

E-27 15 / 20 W
Bajo consumo
Energy saving



NATALI 60

Pie salón
Floor lamp

E-27 15 / 25 W
Bajo consumo
Energy saving



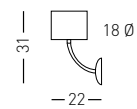
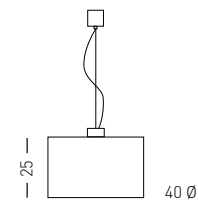

PANTALLA
Malla blanca
METAL
Aluminio mate
CABLE
Transparente

SHADE
White mesh
METAL
Matt aluminium
WIRE
Transparent

NATALI 1C40

Colgante individual
Single suspension
Peso / Weight 3,00 kg

E-27 15 / 25 W
Bajo consumo
Energy saving



NATALI 1AP18

Aplique
Wall light

E-27 15 / 25 W
Bajo consumo
Energy saving



Oceana

DESIGN:
MODI&S DESIGN TEAM

Oceana no es sólo una lámpara.
Oceana es una pecera sin peces cautivos, una tierra sin barreras hipócritas, un jarrón sin flores amputadas, una cabeza sin remordimientos, una ilusión sin engaño.
Oceana es un vientre preñado de vida, de ideas, de luz.

*Oceana is not just a lamp.
Oceana is a fish tank without captive fish, a land without hypocritical barriers, a vase without amputated flowers, a head without remorse, an illusion without a trick.
Oceana is full of life, of ideas, of light.*

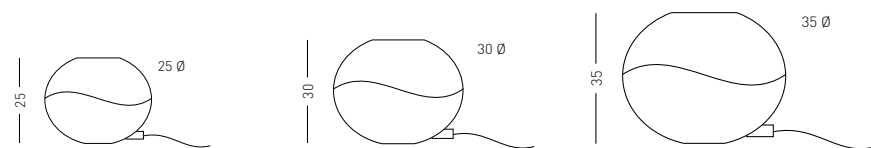

OCEANA 10	OCEANA 20	OCEANA 30
Sobremesa Table lamp	Sobremesa Table lamp	Sobremesa Table lamp
E-27 60 W Cúpula decorativa cromo Decorative chrome crown	E-27 60 W Cúpula decorativa cromo Decorative chrome crown	E-27 60 W Cúpula decorativa cromo Decorative chrome crown

CRISTAL
Cristal transparente
y blanco
METAL
Cromo
CABLE
Transparente

GLASS
Transparent and white
METAL
Chrome
WIRE
Transparent

Penelope

DESIGN:
MODISS DESIGN TEAM

Sólo un cristal soplado artesanalmente podía servir de homenaje a la heroína de Ítaca. Para condensar su atractivo, su calidez y su impenetrable misterio era necesario jugar con las transparencias y las opacidades, con las simetrías y los vacíos, con lo aparente y lo oculto, con la penumbra y la difusión de la luz en toda su riqueza de matices... Al mirarla, veo en Penélope una metáfora de amor y esperanza en esta época de fatigados Ulises ansiosos por encontrar su hogar.

Only hand-blown glass could be enough to render tribute to this heroine of Ithaca. To condense her attractiveness, her warmth and her impenetrable mystery, it was necessary to play with transparencies and opaqueness, with symmetry and emptiness, with the apparent and the hidden, with twilight and diffused light in all its wealth of shades... On seeing it, I see in Penelope a metaphor of love and hope in this time of weary Ulysses' anxious to get home.

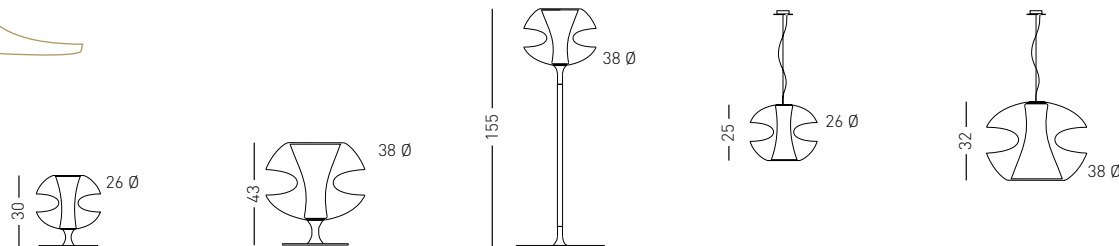

PENELOPE 10	PENELOPE 20	PENELOPE 50	PENELOPE 1C10	PENELOPE 1C20
Sobremesa Table lamp	Sobremesa Table lamp	Pie salón Floor lamp	Colgante individual Single suspension Peso / Weight 4,00 kg	Colgante individual Single suspension Peso / Weight 7,00 kg
G-9 48 W	G-9 48 W	G-9 48 W	G-9 48 W	G-9 48 W

CRISTAL
Cristal soplado transparente
Cristal opal blanco

METAL
Aluminio satinado
Base circular

CABLE
Transparente

GLASS
Transparent blown glass
White glass

METAL
Satin aluminium
Round base

WIRE
Transparent



Pieza de CRISTAL SOPLADO
ARTESANALMENTE
Variaciones estéticas sutiles (espesor, color,
burbujas) forman parte de sus características.

*HAND-MADE MOUTH-BLOWN GLASS piece.
Subtle aesthetical variations (thickness, colour,
bubbles) are features of fine glass.*



Plamira

DESIGN:
MODISS DESIGN TEAM

Cualquiera que haya estado en el desierto lo puede atestiguar: no hay luz más cálida que la que reflejan las dunas de arena al atardecer. Una doble pantalla de seda con un cristal arenado es el material que predomina en el interior de esta lámpara, cuyo nombre recuerda al de una legendaria ciudad perdida con la que soñaron muchos exploradores.

Anyone who has ever been to the desert will vouch for it: the warmest light in the world is the light reflected from sand dunes at nightfall. A double silk shade with sanded glass is the predominant material inside this lamp, whose name recalls a legendary lost city that has appeared in the dreams of many an explorer.

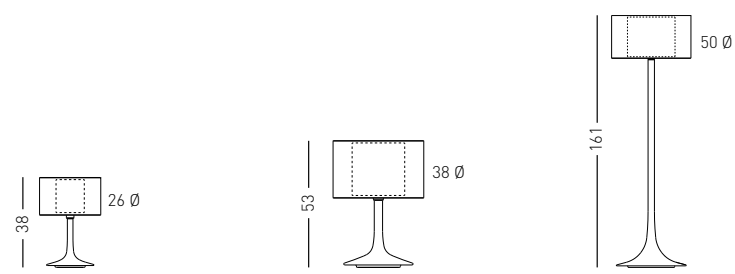

PLAMIRA 10

PLAMIRA 30

PLAMIRA 50

Sobremesa
Table lamp

Sobremesa
Table lamp

Pie salón
Floor lamp

E-14 42 W

E-27 52 / 70 W

E-27 70 W



PANTALLA

EXTERIOR: Tela de seda bordada antracita
Tela blanca
Tela negra
INTERIOR: Cristal rayado arenado

CUERPO

Fibra de vidrio lacado blanco brillo
Fibra de vidrio lacado negro brillo

CABLE

Transparente

SHADE

OUTER: Anthracite cloth
White cloth
Black cloth
INTERIOR: Frosted striped crystal

BODY:



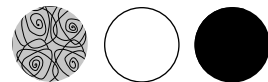

White lacquered fiber glass
Black lacquered fiber glass

WIRE:

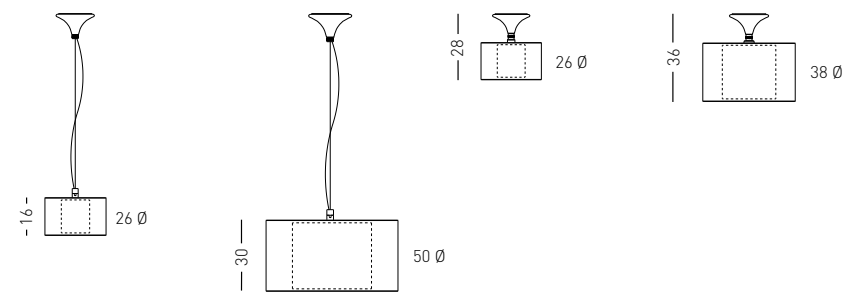
Transparente





PLAMIRA 1C10	PLAMIRA 1C50	PLAMIRA 1PL10	PLAMIRA 1PL30
Colgante individual Single suspension Peso / Weight 2,00 kg	Colgante individual Single suspension Peso / Weight 4,50 kg	Plafón Ceiling lamp	Plafón Ceiling lamp
E-14 42 W	E-27 70 W	E-14 42 W	E-27 52 / 70 W
			

rebecca

DESIGN:
MODISS DESIGN TEAM

Rebecca personaje de novela, protagonista de uno de los films del genio Hitchcock... ¿Qué tendrá este nombre que tanto nos inspira? Es sobria, serena, enigmática, segura, perspicaz... pero, ¿y nuestra Rebecca? Ella, además, nos seduce con un toque de locura en rojo... ¿qué enigma esconde esta dama de seda envuelta en una estola de cristal?

Rebecca, a literary character, a star in one of Hitchcock's brilliant films... What is so inspiring about this name? She is sober, serene, enigmatic, confident, perceptive... but what about our Rebecca? She also seduces with a touch of red madness... What enigma is hidden by this silk lady wrapped in her glass stole?

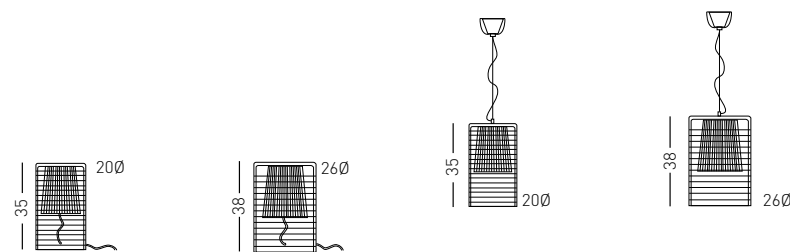

REBECCA 10	REBECCA 20	REBECCA 1C10	REBECCA 1C20
Sobremesa Table lamp	Sobremesa Table lamp	Colgante individual Single suspension Peso / Weight 5,50 kg	Colgante individual Single suspension Peso / Weight 6,50 kg
E-14 11 / 18 W Bajo consumo Energy saving	E-14 11 / 18 W Bajo consumo Energy saving	E-14 11 / 18 W Bajo consumo Energy saving	E-14 11 / 18 W Bajo consumo Energy saving

PANTALLA
Cinta seda blanca
Cinta seda negra
CRISTAL
Tallado transparente
METAL
Cromo brillo
Oro satinado
CABLE
Textil rojo

SHADE
White silk strip
Black silk strip
GLASS
Carved transparent crystal
METAL
Chrome
Satin gold
WIRE
Red textile

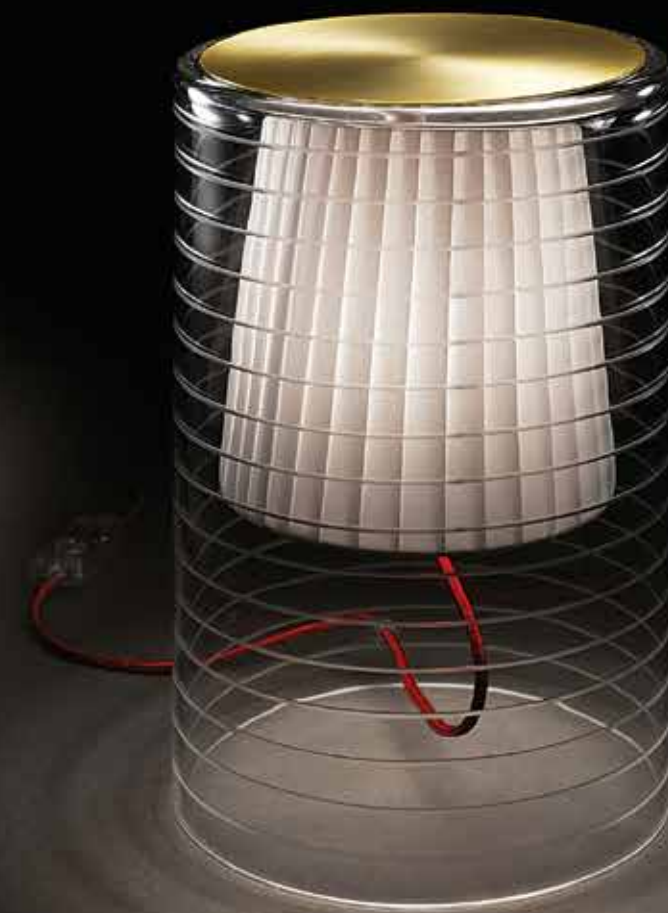



ROSSANA

DESIGN:
MOD/SS DESIGN TEAM

Rossana es una síntesis brillante del carácter femenino en formas y luminosidad. Es el juego de la seducción tintado por la transparencia, es una voz sugerente y un susurro impregnado de deseo, todo ello en un diseño que nos transporta a un pasado más presente que nunca.

Rossana is a brilliant synthesis of the female character in shape and luminosity. It is a game of seduction with the hues of transparency, a suggestive voice and a whisper heavy with desire - all this in a design that takes us back to a past more present than ever.

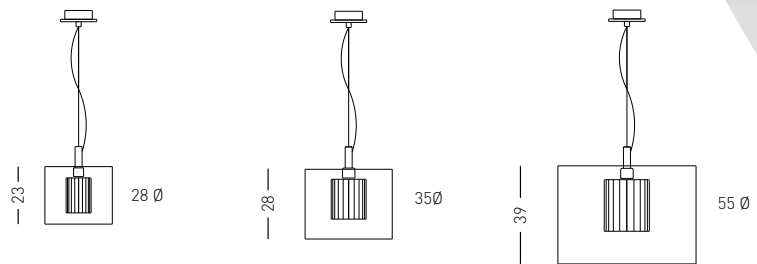

ROSSANA 1C10	ROSSANA 1C20	ROSSANA 1C50
Colgante individual Single suspension Peso / Weight 2,50 kg.	Colgante individual Single suspension Peso / Weight 4,00 kg	Colgante individual Single suspension Peso / Weight 8,00 kg
E-14 42 W	E-27 52 / 70 W	E-27 70 W



PANTALLA EXTERIOR
Lino poliéster blanco / Beige / Visón
PANTALLA INTERIOR
Cristal rayado arenado
METAL
Cromo brillo
CABLE
Textil gris

OUTER SHADE
White linen polyester / Beige / Mink
INTERIOR SHADE
Frosted stripped crystal
METAL
Bright chrome
WIRE
Grey textil

TG GANCEDO
Telas, Moquetas y Papeles Pintados

ROSSANA

CRYSTAL
Transparente

PANTALLA EXTERIOR
Lino poliéster blanco
Beige / Visón

PANTALLA INTERIOR
Cristal rayado arenado

METAL
Cromo brillo

CABLE
Textil gris

GLASS
Transparent

OUT SHADE
White linen polyester
Beige / Mink

INTERIOR SHADE
Frosted stripped crystal

METAL
Bright chrome

WIRE
Grey textil

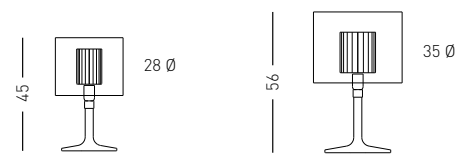

ROSSANA 10 ROSSANA 20

Sobremesa
Table lamp

Sobremesa
Table lamp

E-14 42 W E-27 42 W





Serena

DESIGN:
MODISS DESIGN TEAM

Al verla encendida por primera vez, cuando era todavía un prototipo, su luz me inundó de bienestar. No es nada nuevo. De hecho, el mismo Fray Luis de León percibió que, a veces, milagrosamente,
 "el aire se serena,
 y viste de hermosura y luz no usada"
 Espero que Serena sea la intersección entre el poeta, Modiss y nuestros seguidores.

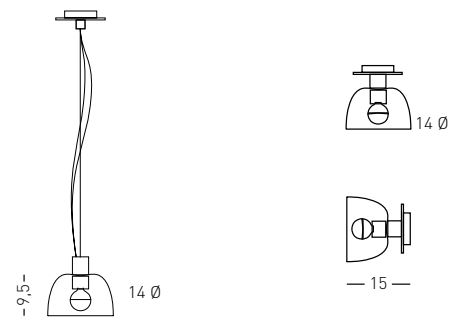
*When I saw it switched on for the first time, when it was still a prototype, its light filled me with a sense of wellbeing. That's nothing new. In fact, Fray Luis de León himself perceived that sometimes and miraculously,
 "the air becomes calm,
 and dresses itself with beauty and unused light"
 I hope that Serena will be the intersection between the poet, Modiss and our supporters.*



SERENA 1C14	SERENA 1AP14
Colgante individual Single suspension Peso / Weight 1,50 kg	Aplique / Plafón Wall lamp / Ceiling lamp
E-14 40 W R50 Reflector decorativo cromo Decorative chrome reflector	E-14 40 W Cúpula decorativa cromo Decorative chrome crown
	



CRISTAL
Topacio
Transparente
METAL
Cromo
CABLE
Transparente

GLASS
Topaz
Transparent
METAL
Chrome
WIRE
Transparent





Sofía

DESIGN:
MODISS DESIGN TEAM

Con 17, cuando presumíamos de "melena al viento" mientras escuchábamos a los Stones, un amigo y yo planeábamos qué íbamos a hacer con nuestras vidas. Él decidió estudiar filosofía y aprendió a ser un amante del conocimiento (¡cómo puede la etimología determinar el destino de un hombre!). Yo, en cambio, opté por Sofía a secas y, por pudor, no diré lo que aprendí. Esta sobremesa resplandeciente de cristal es un recuerdo, precisamente, a las sobremesas con los amigos que me enorgullezco de conservar.

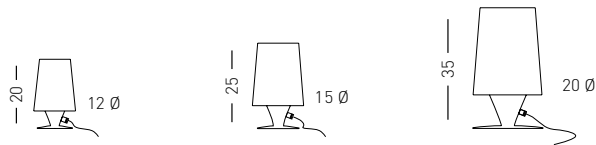

When I was 17, when we had "long hair in the wind" while listening to the Stones, a friend and I made plans about what we were going to do with our lives. He decided to study philosophy and learnt to be a lover of knowledge (how can etymology determine man's destiny!). I, on the other hand, just chose Sofía, and in modesty I will not tell you what I learnt. This shining glass table lamp is exactly a reminiscence of the times after meals sitting at the table with my friends that I am proud to remember.



SOFIA 10

SOFIA 20

SOFIA 30

Sobremesa Table lamp	Sobremesa Table lamp	Sobremesa Table lamp
E-14 9 / 11 W Bajo consumo Energy saving	E-14 11 / 18 W Bajo consumo Energy saving	E-27 20 W Bajo consumo Energy saving
		



CRISTAL
Cristal opal blanco
CABLE
Transparente

GLASS
White opal glass
WIRE
Transparent

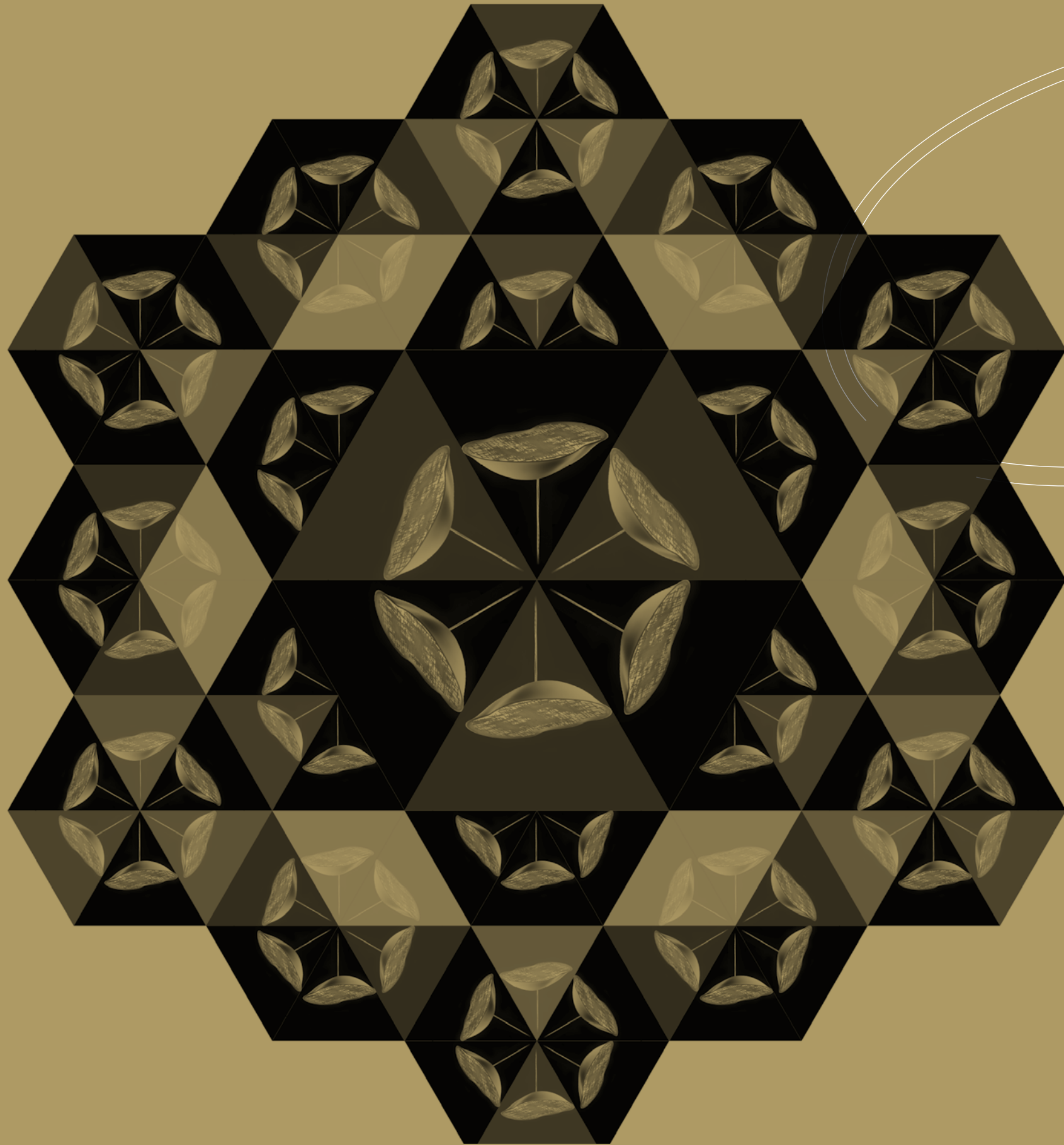

talisse

Talisse

NEW

DESIGN:
Hopf, Nordin

Estoy feliz cuando llueve...
Gotas de lluvia...emergiendo de la naturaleza. Destellos irrepitibles e hipnóticos emitidos por gotas de agua que jamás se dejan atrapar, quedan ahora retenidos en uno de los materiales más nobles que existen: la porcelana. Como la misma naturaleza la porcelana es libre y sensual, no se deja dominar ni controlar y ese misterio hace que cada lámpara sea una pieza única de formas irrepitibles como las mismas gotas de lluvia. Las tradicionales cualidades decorativas de este noble material renacen ahora iluminadas por LEDS ensalzando sus cualidades translúcidas. Reminiscencias contemporáneas emanen del difusor elaborado con tecnología de última generación pero que a su vez nos transporta al romanticismo de antiguos instrumentales náuticos.

*I'm happy when it rains...
Drops of rain... evanescent emergence of nature. An ever changing twinkling that can be admired but never retained, now frozen in space for the first time in one of the oldest and noblest materials made by humankind: porcelain. Like nature itself, porcelain escapes those who wish to force and control it, its mysteries rather waiting to be embraced and exploited anew with each individual form. As the nature of illumination is headed for a new era; the traditional decorative qualities of porcelain, its diffuse translucence and reflectance are reborn with a new purpose by LED. The brass suspension adds a further twist; once used in the realm of nautical and astronomic instruments of old, it is revived here in a decidedly contemporary form, an angular pattern derived from slicing a meteorite, diffusing the light.*

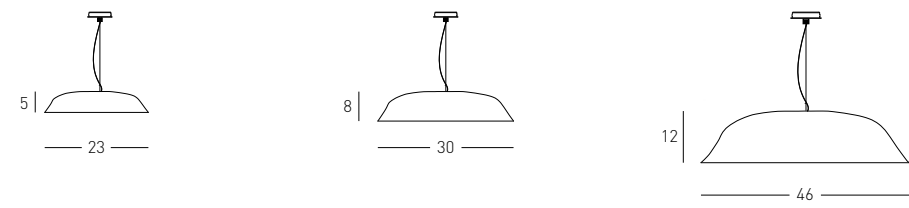
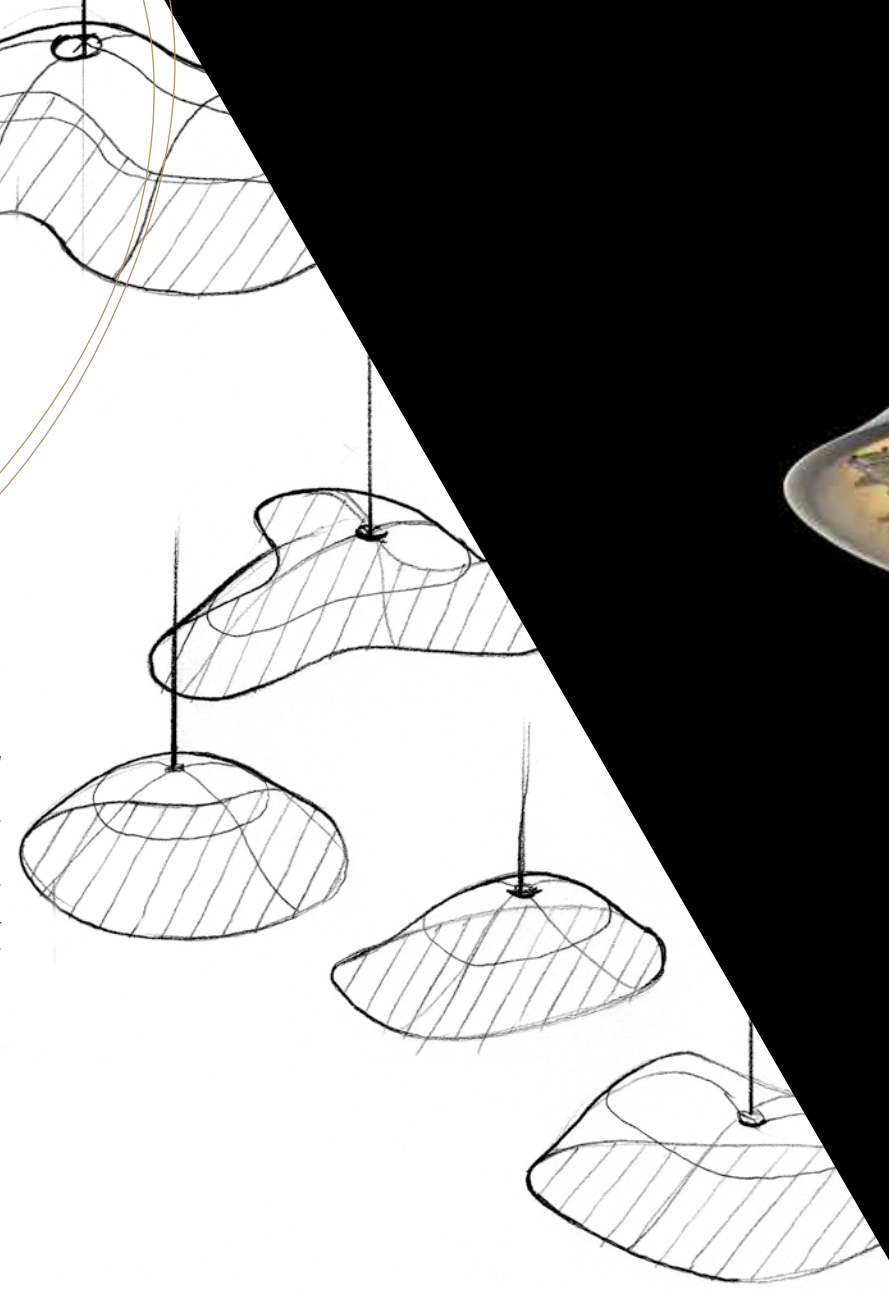

TALISSE 1C20	TALISSE 1C30	TALISSE 1C50
Colgante individual Single suspension Peso / Weight 2,50 kg	Colgante individual Single suspension Peso / Weight 3,80 kg	Colgante individual Single suspension Peso / Weight 5,20 kg
LED 10 W - 700 mA	LED 20 W - 700 mA	LED 30 W - 700 mA



PANTALLA
Porcelana Sargadelos
METAL
Difusor de latón
CABLE
Transparente

SHADE
Sargadelos Porcelain
METAL
Brass diffuser
WIRE
Transparent







tusscana

DESIGN:
MODISS DESIGN TEAM

A menudo me cuesta acertar de dónde surgió la inspiración para crear una lámpara; el nombre suele darme la clave. Al parecer, mi subconsciente es un sujeto hiperactivo, que almacena imágenes de los bosques y los riachuelos, de las callejuelas y las casas, para después enviarlas cifradas a mi mano. Creo que en esta ocasión, los impulsos eléctricos nacen en Arezzo.

At times I wonder where the inspiration to create a lamp came from; the name sometimes gives me a clue. Apparently, my subconscious is a hyperactive being which stores images of the forests, streams, alley ways and houses, and later sends them encoded to my hand. I believe this time the electric impulses come from Arezzo.

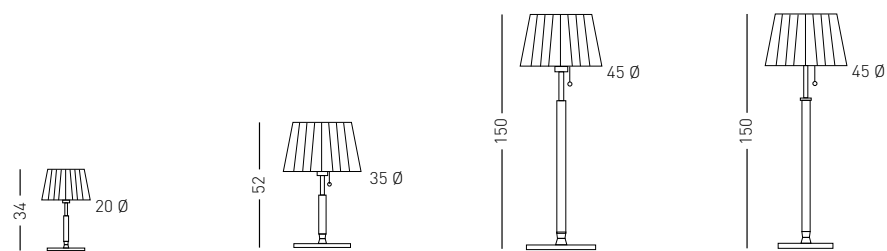

TUSSCANA 10	TUSSCANA 30	TUSSCANA 50	TUSSCANA 60
Sobremesa Table lamp	Sobremesa Table lamp	Pie salón Floor lamp	Pie salón Floor lamp
E-14 28 W	E-27 52 W	E-27 52 / 70 W	E-27 52 / 70 W





PANTALLA
Cinta seda beige / Cinta seda negra / Cinta seda roja
METAL
Aluminio mate
MADERA
Wenge (sólo para Tusscana 60)
CABLE
Transparente

SHADE
Beige silk strip / Black silk strip / Red silk strip
METAL
Matt aluminium
WOOD
Wenge (only for Tusscana 60)
WIRE
Transparent

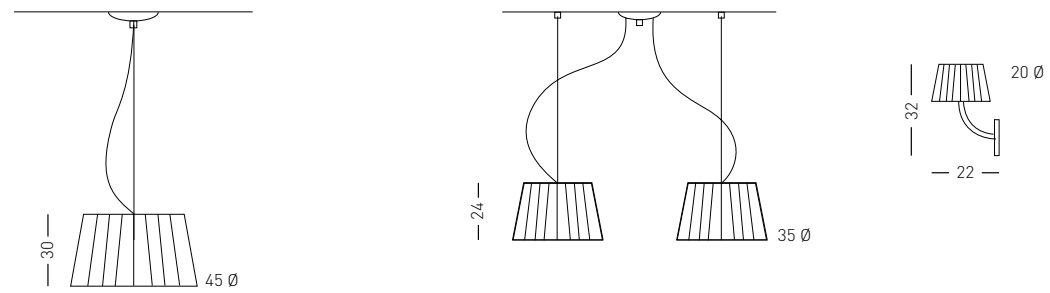



TUSSCANA 1C45 **TUSSCANA 2C35** **TUSSCANA 1AP20**



Colgante individual <i>Single suspension</i> Peso / Weight 2,50 kg	Colgante doble <i>Double suspension</i> Peso / Weight 3,50 kg	Aplique <i>Wall light</i>
2 x E-27 52 / 70 W	2 x E-27 52 / 70 W	E-14 28 W
		

PANTALLA
Cinta seda beige / Cinta seda negra / Cinta seda roja
METAL
Aluminio mate
CABLE
Transparente

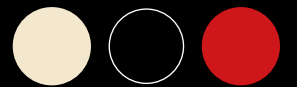
SHADE
Beige silk strip / Black silk strip / Red silk strip
METAL
Matt aluminium
WIRE
Transparent

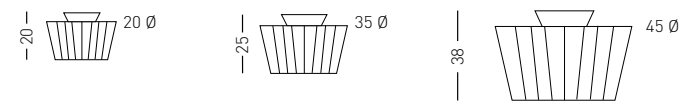



TUSSCANA 1P20	TUSSCANA 1P35	TUSSCANA 1P45
Plafón Ceiling lamp	Plafón Ceiling lamp	Plafón Ceiling lamp
E-14 42 W	E-27 52 / 70 W	E-27 70 W
		

PANTALLA
Cinta seda beige / Cinta seda
negra / Cinta seda roja
METAL
Aluminio mate
CABLE
Transparente

SHADE
Beige silk strip / Black silk strip
Red silk strip
METAL
Matt aluminium
WIRE
Transparent

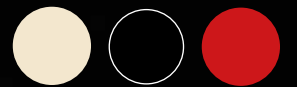



tybo

DESIGN:
MODISS DESIGN TEAM

No la necesitaba, pero -¡por si acaso!- a lo largo de estos años a su lado le he deseado suerte innumerables veces. Tantas que he gastado la frase. Ya no me sirven las palabras. Por eso le dedico esta lámpara, este trébol de cuatro hojas particular, redondo y esbelto a la vez, desenfadado, lleno de luz, de vida... Ésa es la mejor suerte, la vida.

She didn't really need it but -just in case!- over the years with her I've wished her luck countless times. In fact, I've done it so often that I've worn the sentence out. Words are no use to me now. That's why I'm dedicating this light to her, this particular fourleafed clover, simultaneously round and slender, selfassured, full of light and life... That's the best luck you can have: life itself.



Modelo premiado con el GOOD DESIGN from The Chicago Athenaeum
Award Winner of the GOOD DESIGN from The Chicago Athenaeum USA

Pieza de CRISTAL SOPLADO ARTESANALMENTE
Variaciones estéticas sutiles (espesor, color, burbujas) forman parte de sus características.
HAND-MADE MOUTH-BLOWN GLASS piece. Subtle aesthetical variations (thickness, colour, bubbles) are features of fine glass.

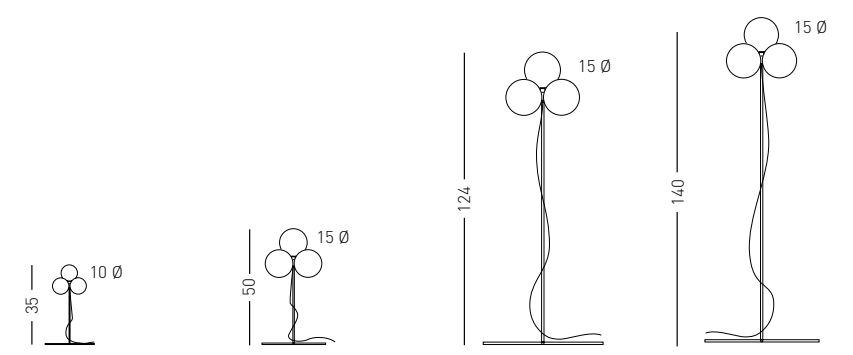

TYBO 10	TYBO 30	TYBO 50	TYBO 60
Sobremesa Table lamp	Sobremesa Table lamp	Pie salón Floor lamp	Pie salón Floor lamp
4 x G-9 20 W	4 x G-9 33 W	4 x G-9 33 W	4 x G-9 33 W

CRISTAL
Opal blanco
METAL
Cromo
CABLE
Transparente

GLASS
White glass
METAL
Chrome
WIRE
Transparent



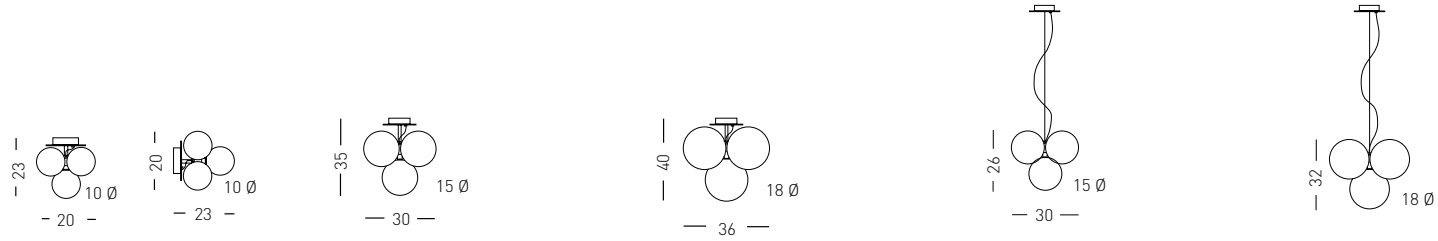

TYBO 1AP10	TYBO 1PL15	TYBO 1PL18	TYBO 1C15	TYBO 1C18
Aplique / plafón Wall lamp / ceiling lamp	Plafón Ceiling lamp	Plafón Ceiling lamp	Colgante individual Single suspension Peso / Weight 3,50 kg	Colgante individual Single suspension Peso / Weight 4,00 kg
4 x G-9 20 W	4 x G-9 33 W	4 x G-9 33 W	4 x G-9 33 W	4 x G-9 33 W

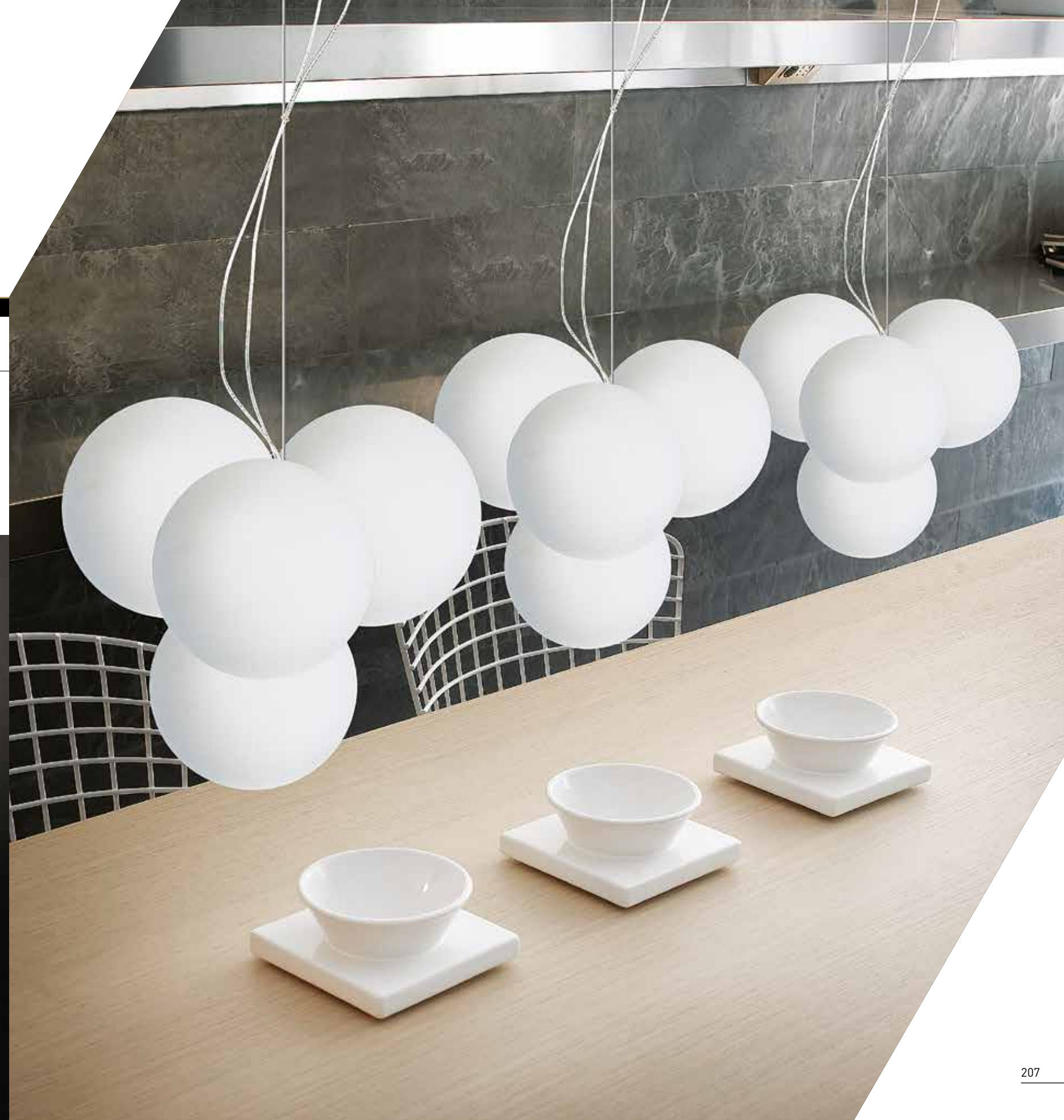





Valentina

DESIGN:
MODISS DESIGN TEAM

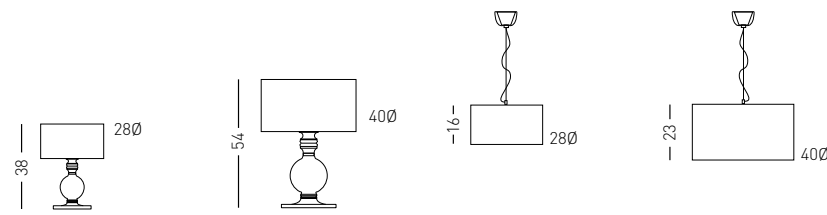
Soberbia, majestuosa, una pieza que es en sí misma una joya. Un cuerpo de cristal tallado sobre el que se asienta una cabeza coronada de tela como si de una reina se tratara. Al pasar delante de Valentina deberán bajar la vista como muestra de humildad, sabiendo que ninguna otra es capaz de igualar su belleza. Ella es nuestra Reina de Corazones.

Superb, majestic, an object that is a jewel in itself. A cut-glass body crowned with a head that is topped with clothly material, as if she were a queen. When your path crosses Valentina you should lower your gaze in humility, knowing that no-one else can match her beauty. She is our Queen of Hearts.



VALENTINA 20	VALENTINA 30	VALENTINA 1C20	VALENTINA 1C30
Sobremesa Table lamp	Sobremesa Table lamp	Colgante individual Single suspension Peso / Weight 3,50 kg	Colgante individual Single suspension Peso / Weight 5,50 kg
3 x G-9 20 W	3 x G-9 33 W	E-14 42 W	E-27 70 W
			



PANTALLA
Tela negra
BASE
Cristal tallado transparente
METAL
Cromo
CABLE
Transparente

SHADE
Black cloth
BASE
Carved transparent crystal
METAL
Chrome
WIRE
Transparent

Zinnia

NEW

DESIGN:
Nadia Corsaro & Marcelo Dabini

Elegancia y calidez

Salvaje... sus pétalos delgados y alargados rodean su yema de luz. Su carácter representa la inocencia. Iluminada refleja confianza y calidez. Ésta flor es soñadora y su aura de luz relaja las mentes de los que la rodean. La primera flor que devuelve la luz perdida a la naturaleza... Nunca antes dar vida a una flor había sido tan sencillo bello e intuitivo.

Sus finas lamas conservan la pureza y el color de la naturaleza. Sin adornos... translúcida...natural... tal y como viene al mundo.

Elegance and warmth

Wild... Its slim and elongated petals surround its light. Its character represents the innocence. When lighting, it reflects trust and warmth. This flower is dreamy and its light aura relaxes the minds of those surrounding it. The first flower that revives lost light to nature. Bringing a flower to life has never been so easy, lovely and intuitive.

Behind a meticulous recycling technique, its thin layers keep themselves pure and preserve their color from the authentic wood, extracted from nature. Unadorned... translucent... natural... as it comes to the World.

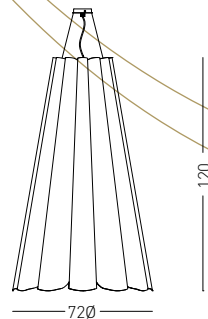
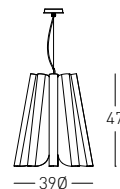

ZINNIA 1C40

Colgante individual
Single suspension
Peso / Weight 2,5 kg

LED E-27 10 W
(Recomendado / Recommended)



ZINNIA 1C70

Colgante individual
Single suspension
Peso / Weight 12 kg

3 x LED E-27 10 W
(Recomendado / Recommended)



PANTALLA

Chapa de madera reconstituida

Natural

Tabaco

CABLE

Negro

SHADE

Reconstituted wood veneer

WIRE

Black



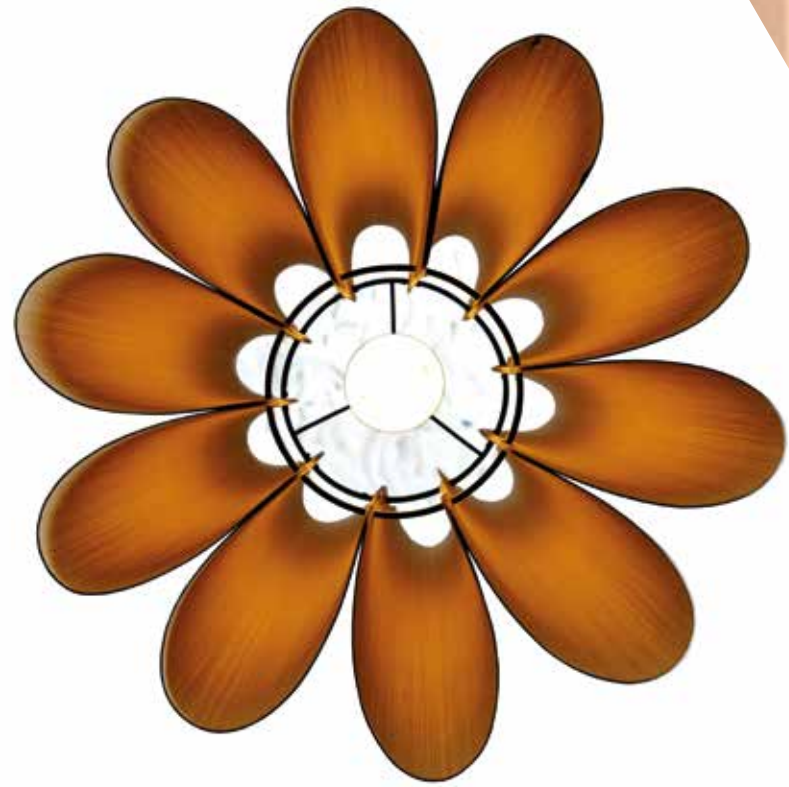

PANTALLA
Chapa de madera reconstituida
Natural
Tabaco

CABLE
Negro

BASE
Negra

SHADE
Reconstituted wood veneer

WIRE
Black

BASE
Black

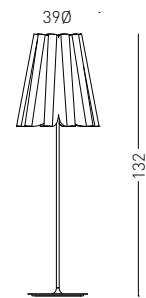

ZINNIA 50

Pie salón
Floor lamp

LED E-27 10 W
[Recomendado / Recommended]



ZINNIA 60

Pie salón
Floor lamp

LED E-27 10 W
[Recomendado / Recommended]

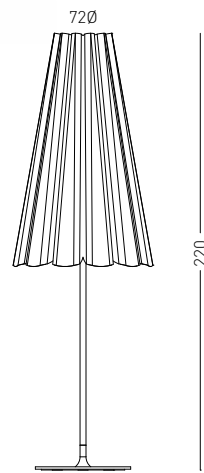

ZINNIA 70

Pie salón
Floor lamp

3 x LED E-27 10 W
[Recomendado / Recommended]







designers



Mitjadotzena



Nadia Corsaro & Marcelo Dabini



Burkhard Dämmer



Estela & Nereo



Hopf, Nordin



Josep Sancho



Lagranja design



Luis Pons



Ramón Benedito



Valéry Bouvier



Roger Vancells

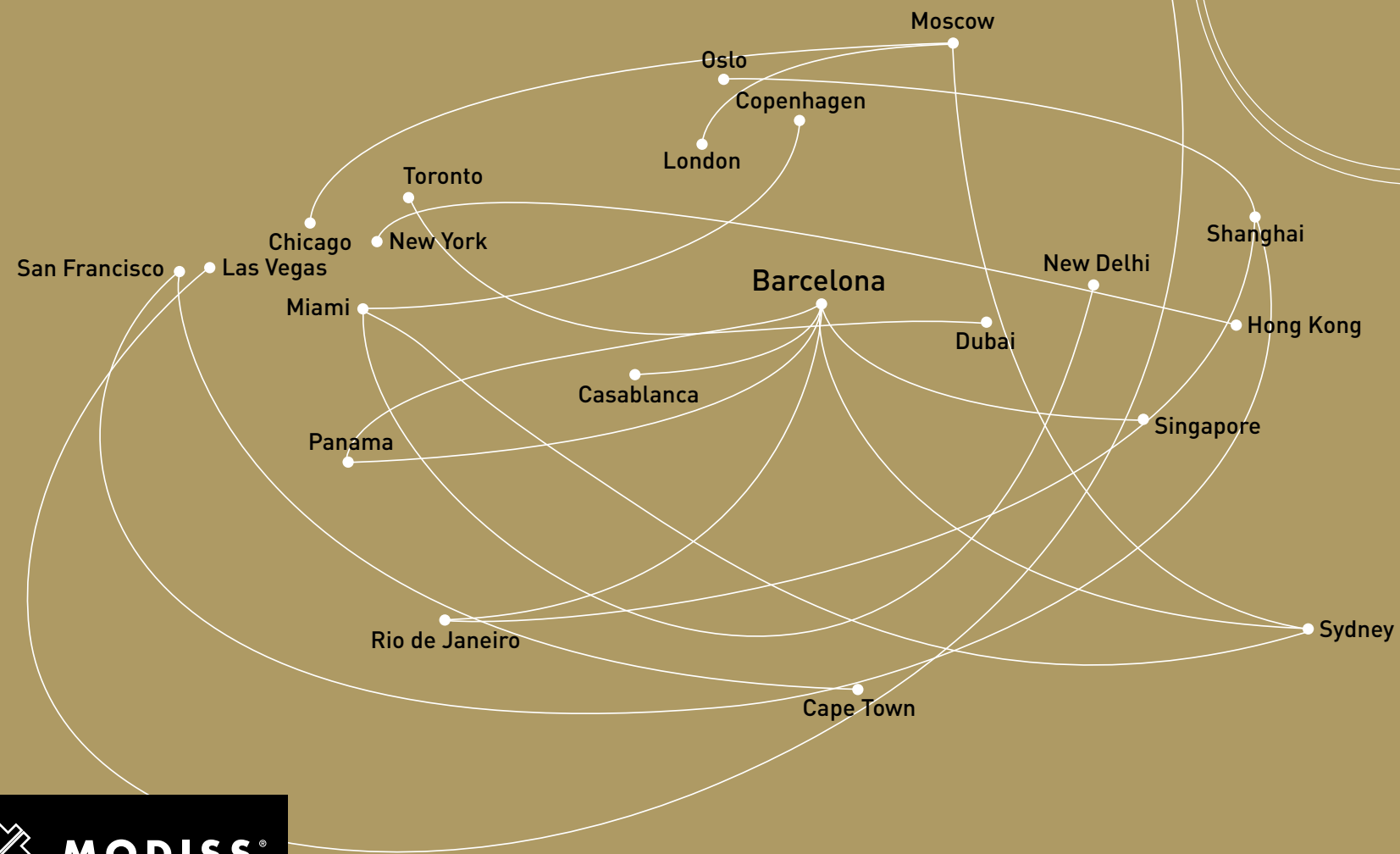

contract

MODISS CONTRACT DIVISION

Rogamos dirijan sus consultas de Cotizaciones de Proyectos de Iluminación a:

contract@modiss.com - TEL. +34 934 320 711.

Un Equipo de Profesionales estará a su disposición para consultas especiales de Cotizaciones de Grandes Cantidades, solicitudes de Modificaciones de Producto de Catálogo General o desarrollo de Diseños Exclusivos hechos a Medida del Cliente.

We request direct all inquiries regarding Lighting Project Quotations to our email:

contract@modiss.com or Tel. +34 934 320 711.

Our specialized team is at your disposal for expert advise on: Special Quotation for Large Projects, Product Modifications of General Catalogue Designs or development of Custom Made Solutions and Exclusive Products in accordance with the client requirements.

Lighting Projects

AC Hotel - Madrid ARTS RITZ CARLTON Hotel - Barcelona ATLANTIC KEMPINSKI Hotel - Hamburg BARCELO CERVANTES Hotel - Oviedo BEACON Court - Dublín CAMPANILE Barcelona Sud Hotel - Cornellà CONFORTEL Atrium Hotel - Madrid CONFORTEL Barcelona Hotel - Barcelona CONFORTEL Suites Hotel - Madrid CORTEFIEL - Retail Stores CRAM Hotel - Barcelona CROWN PLAZA Hotel - Helsinki DOLCE SITGES Hotel - Barcelona DON CANDIDO Hotel - Terrassa EL AL AIRLINES Lobby - New York Airport FORUM FAD - Barcelona HESPERIA Ciutat de Mallorca Hotel - Mallorca HESPERIA Hotel - Bilbao HESPERIA London Victoria Hotel - London HESPERIA Zaragoza Hotel - Zaragoza HIGH TECH Petit Palace - Barcelona HOPE Street Hotel - Liverpool HUSA Cathedral Hotel - Almería IBOO Restaurants - Spain LE MERIDIEM - New Delhi MACIA ALFAROS Hotel - Córdoba MANGO Retail Stores - Worldwide MANOS Hotel - Belgium MARRIOT Renaissance Hotel - La Concha MASSIMO DUTTI Retail Stores - Worldwide MELIA Bodegas Laus - Barbastro MELIA Lebreros Hotel - Sevilla MELIA Princesa Hotel - Madrid MELIA Sol y Nieve - Granada NH Belagua

Hotel - Barcelona NH Calderón Hotel - Barcelona NH Constanza Hotel - Barcelona NH Duc de la Victoria Hotel - Barcelona NH Les Corts Hotel - Barcelona - NH Pirineos Hotel - Lérida NH Schiller Hotel - Ámsterdam NH Viena Airport Hotel - Viena PALACE HOTEL Noordwijk Hotel - Holland PARADORES NACIONALES - Spain PIERRE & VACANCES RESIDENCE CANNES BEACH - Cannes PNB DARBY PARK - Kuala Lumpur POLARIS WORLD Convention Center - Murcia PRECIADOS Hotel - Madrid PUERTO ANTILLA GRAND Hotel - Sevilla RADISSON HESPERIA Helsinki - Helsinki RESIDENCIAS BETLEM - Mallorca SHERATON Hotel - Las Palmas SILKEN Hotel - Burgos SOL MELIA Hotels - Worldwides SWISS Hotel - Tallin TRYP Hotel - Zaragoza Van An ampt van nijkerk - Finland VINCCI Capitol - Madrid VINCCI Condal Mar - Barcelona VINCCI SOHO Hotel - Madrid VIPS Restaurants - Spain W STARWOOD Hotels - Hong Kong W STARWOOD Hotels - Qatar Doha W STARWOOD hotel VELA - Barcelona



Todos los productos MODISS están diseñados y fabricados teniendo en cuenta las siguientes Directivas del Parlamento Europeo: 2006/95/CE Directiva de Baja Tensión – 89/336/CE Directiva de Compatibilidad Electromagnética – 93/68/CE Marcado CE – 2002/96/CE Gestión de Residuos.

All MODISS products are designed and manufactured in accordance with the following Directives of the European Parliament and the Council: 2006/95/CE Low Tension Directive – 89/336/CE Electromagnetic Compatibility Directive 93/68/CE CE Marking Directive – 2002/96/CE Directive on Waste.

Este catálogo anula todos los anteriores. / *This catalogue invalidates all previous ones.*

MODISS se reserva el derecho a anular cualquier modelo, así como a modificar sin previo aviso las descripciones y medidas que, a título informativo, se detallan sobre los productos.

MODISS reserves the right to cancel any model and to change without prior warning product descriptions and measurements given for information purposes.



MODISS®

Etiqueta identificable que certifica, garantiza y autentifica los diseños originales de MODISS.
Identifiable label which certifies, guarantees and authenticates original MODISS designs.

MANUFACTURED IN BARCELONA, 2014.